

Collection: Stella

Product #: CHB0070-05

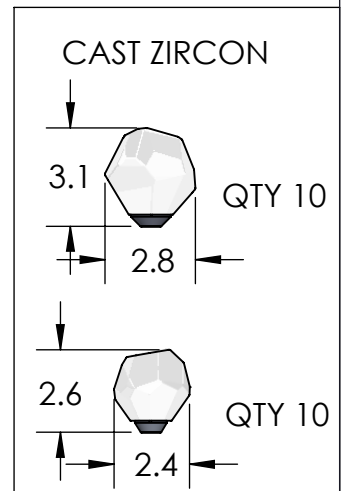
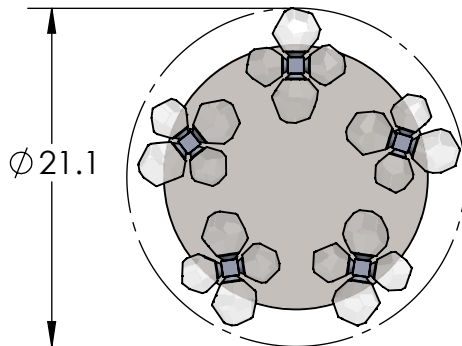
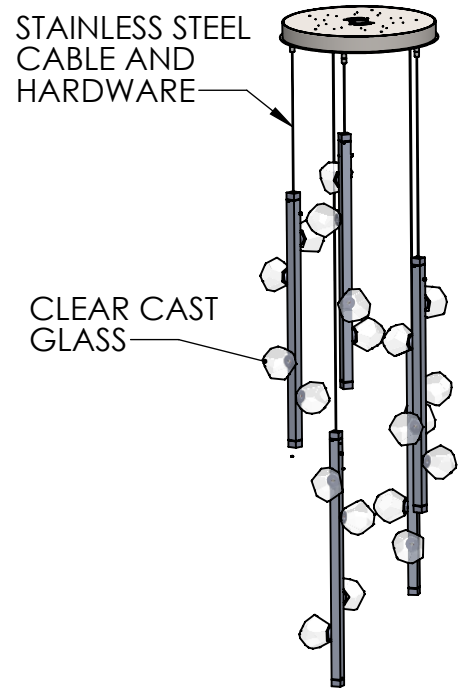
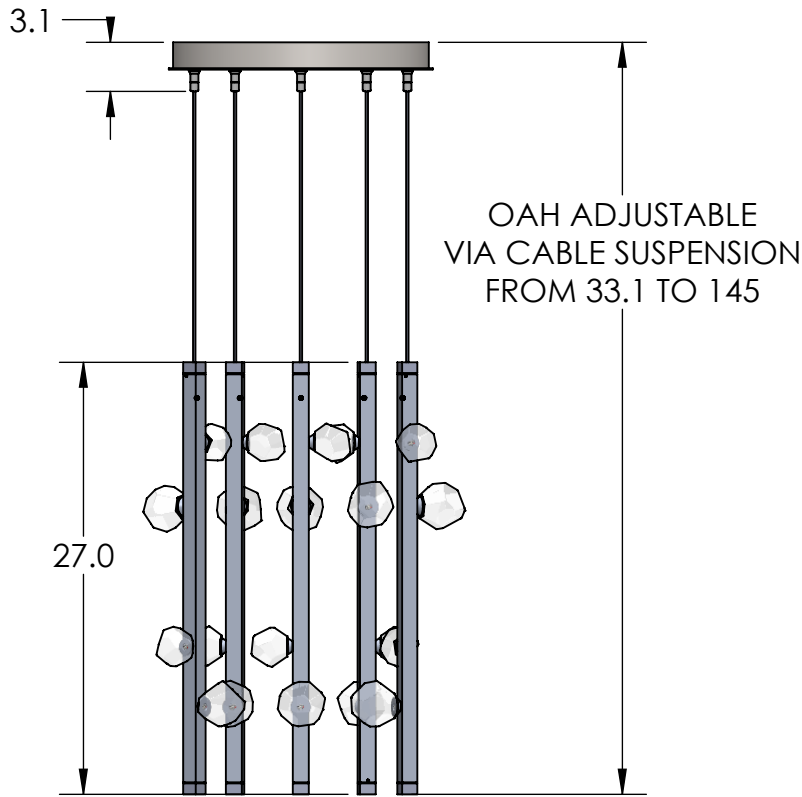

All dimensions are shown in inches unless otherwise stated.
Visit hammertonstudio.com for product options.

12/8/2020 (A)

Mounting Packet: X	Weight(lbs.): 40	Electrical Type: LED	CCT: 3000K
UL Location: DRY		Elec. Qty: 20	Wattage: 25 Voltage: 120
Finish: SEE WEBSITE FOR OPTIONS		Source Lumens: Ambient: 3100	
Top Diffuser: N/A		Dimmable: Forward/Reverse Phase To 1%	
Bottom Diffuser: N/A		CRI: 93+	Power Factor: >0.9

Canopy Mounting Detail

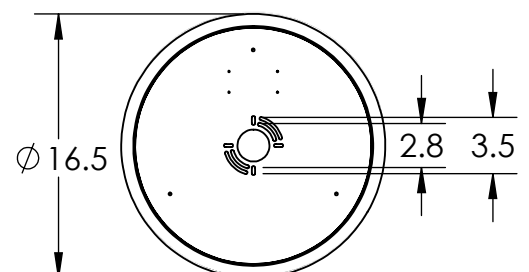

MOUNTS DIRECTLY TO J-BOX

All Hammerton fixtures are handcrafted by artisans. Subtle imperfections reflect the mark of the artisan and should be expected in any handcrafted product. Dimensions may vary up to 7/8".

© Copyright 2020. All rights in design, detail or invention of this drawing are reserved as the property of Hammerton. Any imitation or adaptation without written consent is strictly prohibited.

Hammerton Inc. 217 Wright Brothers Dr. Salt Lake City, UT 84116 (801)973-8095