

# ARTERIO RS

## ERNEST SCONCE

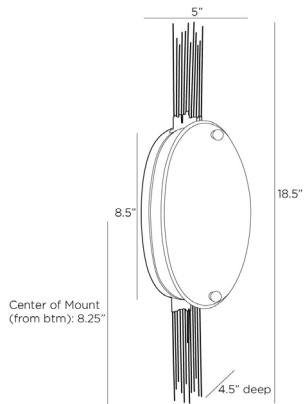

DWI16  
H: 18.5 IN, W: 5 IN, D: 4.5 IN  
Clear  
Contract Suitable As Is

The shield-like Ernest casts an alluring mix of shadow and light wherever it is hung. Recalling a Brutalist brooch, a frame of natural iron, welded with antique-brass, seemingly “pierces” the fixture of clear seeded glass containing a single bulb. Antique brass rivet detail. Finish will vary.

### APPEARANCE

Material	Brass, Glass, Iron
Material Type	Seedy, Weld
Finish	Antique Brass, Natural
Finish Will Vary	true
Top Coat/Sealant	false

### DIMENSIONS

Center Of Mount From Btm	1.5
Center Of Mount From Btm	8.25 IN
Backplate	H: 8.5 IN, W: 4.5 IN, D: 1 IN

### WIRING

Rating	Damp
Suggested Bulb Type	T6
Cord	1 FT, Clear/Silver, SVT
Socket	1, Type B - E12
Photographed Bulb	Small Clear Tubular Bulb
Maximum Watt	25
Voltage	110-120 V

### COMPLIANCY

RoHS	true
------	------

### SHIPPING

Product Weight	3.3 LBS
Gross Weight 1	5 LBS
Shipping Box 1	H: 9.5 IN, L: 20.5 IN, W: 7 IN

### ADDITIONAL INFO

Hanging Orientation	Horizontal and Vertical
---------------------	-------------------------

### REPLACEMENT PARTS

Replacement Part 1	DWI16GLS
--------------------	----------

### CONTRACT

Contract Suitable	true
-------------------	------