

# INSTALLATION INSTRUCTION OF I CONNECTOR

**Turn electricity off at fuse box or circuit breaker box.**

1. Remove flat head set screw from the back of I Connector fitting and use it to fasten Ceiling Plate to I Connector fitting.
2. Remove cover from I Connector fitting. Place track with Ceiling Plate attached to Outlet Box and mark on ceiling or wall the position of the track mounting holes ( **CAUTION** : Arrow mark on I Connector fitting should point to polarity groove on track for proper installation after assembly ).
3. Fasten Ceiling Plate to Outlet Box with two screws. Pull wires from Box thru open hole in I Connector as shown.
4. Cut and strip wires from Box and fasten BK house wire to Brass terminal; WH house wire to Nickel-Plated terminal ;Green Ground house wire to Green Ground terminal by rotating the screws.
5. Push excess wires back to into Outlet Box and recap the cover by screw.

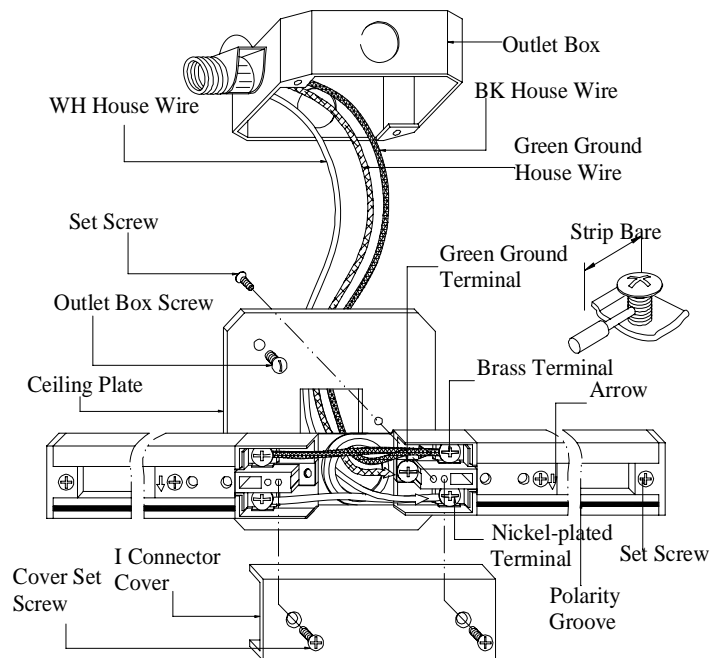

**SAVE THESE INSTRUCTIONS**

**Warning:** To avoid the potential risk of fire and shorting, under any circumstances **should not** you use the connectors and end cap **without** busbar stoppers (Drawings below with "X" mark ) for your track system.

