



CAL LIGHTING

3625 E. Philadelphia St. Ontario CA. 91761 • Tel: 909.947.5200 • Fax:
909.947.5673 • www.calighting.com • service@calighting.com •
Specifications subject to change without notice

Type: _____

Project: _____

Catalog No.: _____

Lamp/Wattage: _____

Drawing:

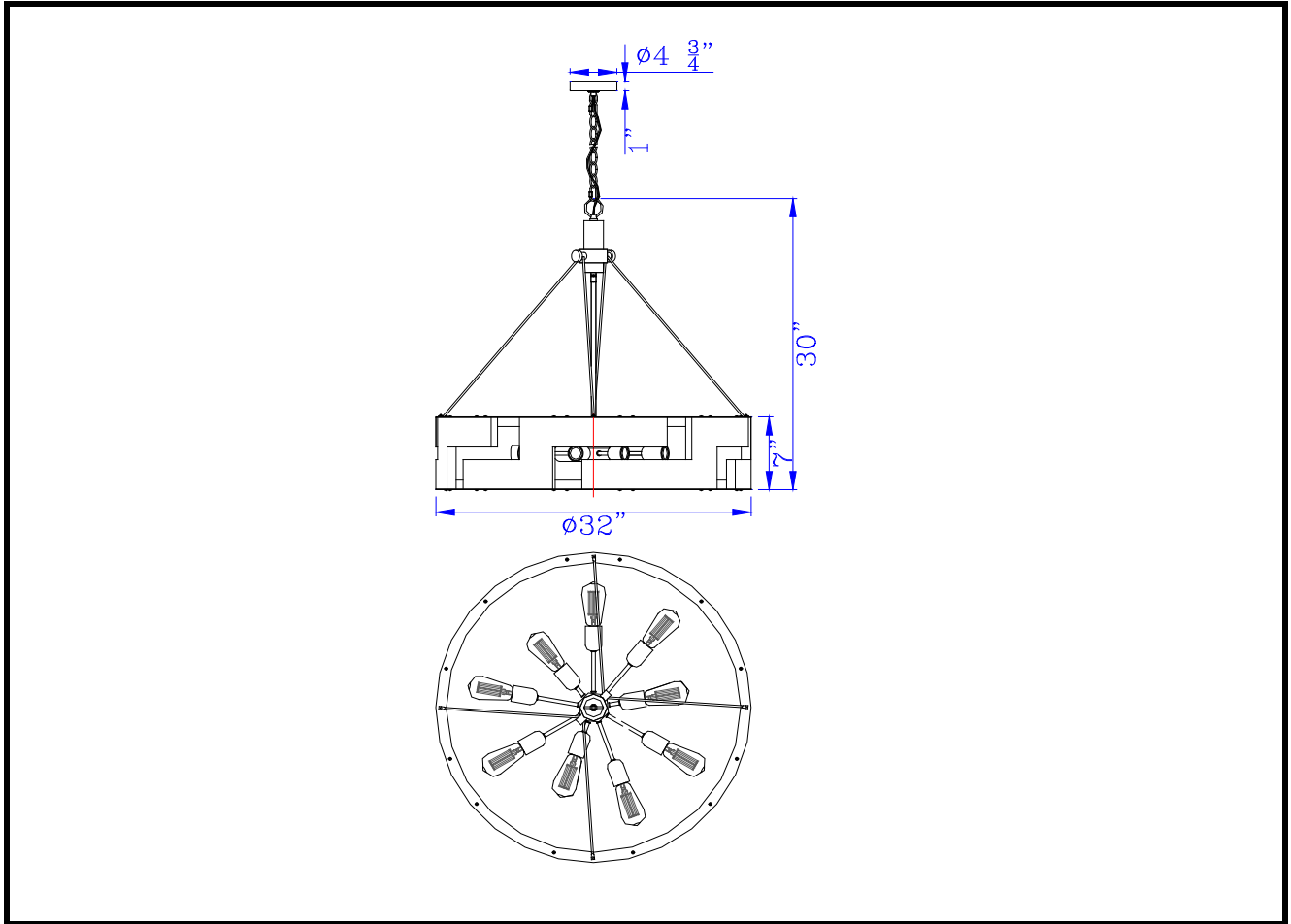

Model No: FX-3670-9
Description: 60W x 9 Bradford metal and wood chandelier
Material: Metal / Wood
Finish : Smoky wood
Height: 30"
Width: 32"
Wattage : 60WX9
Socket : Medium Base (E26)
Bulb: Incandescent
Chain Length:
Wire Length: 6'
Wire Color: Black
Shade No: None
Material: None
Shade size: None
Certificate : 