

ASSEMBLY INSTRUCTIONS

ITEM DESCRIPTION:

ITEM NO.: DRC11	NAME:LEIGHTON CHANDELIER
MATERIAL TYPE: METALL+GLASS	FINISH: ANTIQUE BRASS+ SMOKE LUSTER GLASS
SOCKET TYPE: E26	SOCKET QTY: 7
BULB WATTAGE: TYPE T 60W	
VOLTAGE: 100V-120V	ITEM NET WEIGHT: 24KG

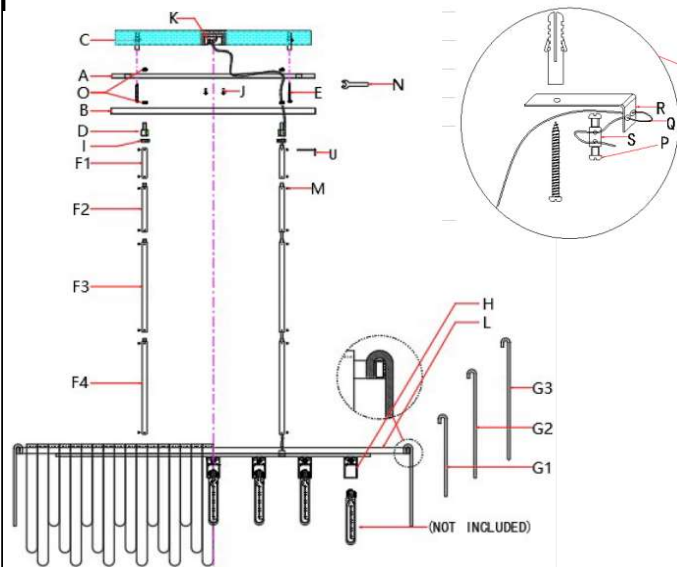

PARTS INCLUDED:

Mounting Plate (A)	Qty:1PC	Plastic Wire Connector(K)	Qty:3PCS
Canopy(B)	Qty:1PC	Lamp body(L)	Qty:1PC
Anchor (C)	Qty:6PCS	Hex Screw (M)	Qty:24PCS
Nipple(D)	Qty:2PCS	Wrench(N)	Qty:1PC
Strengthened Screw(E)	Qty:6PCS	Nuts(O)	Qty:4PCS
Rod(F1,F2,F3,F4)	Qty:8PCS	Screw(P)	Qty:2PCS
Small glass(G1)	Qty:27PCS	Aircraft Wire (Q)	Qty:1PC
Medium glass(G2)	Qty:27PCS	Bracket (R)	Qty:1PC
Large glass(G3)	Qty:27PCS	Coupling (S)	Qty:1PC
Sockets(H)	Qty:7PCS	Allen Wrench(U)	Qty:1PC
Collar (I)	Qty:2PCS		
Mounting Screws(J)	Qty:2PCS		

HARDWARE INCLUDED:

Mounting Screws	2	Hexangular Screw	24
Plastic Wire Connector	3	Allen Wrench	1
Green Ground Screw	1		

TO INSTALL YOU WILL NEED:

- 2 people recommended
- Phillips Screwdriver
- Allen Wrench
- Wrench

These instructions are provided for safety. It is very important that they are read carefully and completely before beginning installation of this chandelier.

We strongly suggest that all hard-wired fixtures must be installed by a professional electrician.

For customer service questions call 1-800-338-2150
Arteriors Home: 972-488-9800 Arteriors Contract: 972-488-9800 Ext. 321



TO ASSEMBLE:

- Shut off the main electrical supply from the main fuse box/ circuit breaker.
 - Carefully unpack all fixture parts and hardware and lay them on a soft surface for assembly.
 - Gently pull wiring down from ceiling junction box and allow to hang.
 - Remove the mounting plate(A) from The canopy(B) by removing 2pcs screw nuts(O) in a counter clockwise direction.
 - Position fixture in desired location on ceiling. The mounting plate features (2) holes for screw mounting. Mark these spots on the ceiling with a pencil to drill holes. Drill 2 holes on these spots and insert anchors(C) into drilled holes.
 - Pass the power wire through the rod (F4),(F3),(F2)&(F1), screw the rod(F4) to lamp body(L) till tight,repeat the same operation on the rod(F3),rod(F2) and rod(F1).When you connect the rods,loosen the small hex screws(M) in the side hole first then tighten with allen wrench(U) after all rods are connected.Be sure all the hexangular screws are tight enough.
 - Drill one hole on the ceiling and insert anchor(C) into drilled hole, then fix bracket(R) to the ceiling with strengthened screw (E) by screwing into anchor(C). Remove the coupling(S) from the aircraft wire(Q) by loosening (2) screws(P). Pass the aircraft wire(Q) through (2) holes on the bracket(R), then pass the aircraft wire(Q) through (2) holes on the coupling(S) and fix with (2) screws(P) as Fig1 .Or you can find more details on next page. Be sure to tighten two screws attached on the coupling(S).
 - Put rod(F1) through the collar loop(I) and canopy(B), and connent the nipple(D) to the rod(F1) then tighten it by turning in a clockwise direction. Repeat the same operations on another side.
 - Connect nipple(D) to the mounting plate(A) with 2pcs of screw nuts(O) as drawing and tighten screw nuts (O) with a wrench.Repeat the same operations(8) on another side.
 - Carefully inspect the chandelier's fixture wires.
Neutral fixture wire: It has very fine ridges molded into its plastic covering.
Hot fixture wire: It has a smooth covering
Ground wire: Bare wire
 - Wrap ground wire of lamp assembly and ground wire of junction box together and fasten together with a wire nut and wrap the connection with electrical tape.
 - Attach the neutral fixture wire from the chandelier to the neutral junction box wire. Fasten each together with a wire nut and wrap the connection with electrical tape.
 - Attach the hot fixture wire from the chandelier to the hot junction box wire. Fasten each together with a wire nut and wrap the connection with electrical tape.
- DO NOT REVERSE THE HOT AND NEUTRAL CONNECTIONS OR SAFETY WILL BE COMPROMISED.
- Gently tuck the wire connections(K) neatly into the ceiling junction box.
 - Attach the mounting plate (A) to the ceiling outlet box using the enclosed mounting screws (J) and tighten screws with a screwdriver.Then secure mounting plate (A) on the ceiling by inserting 2pcs strengthened screws(E) into the anchor(C) and then tighten strengthened screws (E) with a screwdriver.
 - Push canopy (B) and collar loop(I) up to the ceiling and thread the collar loop(I) onto the nipple(D) in mounting plate (A) to secure canopy(B) by turning in a clockwise direction.
 - Attach the small glass (G1), the medium glass (G2) and the large glass (G3) on the lamp body (L) in turn and repeat the same operations on the other glass.
 - Insert 7 TYPE T 60W bulbs (or /CFL 12W OR /LED 10W, not included) into socket(H).
DO NOT EXCEED THE SPECIFIED WATTAGE.
 - Restore power to the junction box and test fixture.

CARE INSTRUCTIONS:

Wipe with a soft, dry cloth. To protect finish, avoid the use of chemicals and household cleaners.

ARTERIOS

AIRCRAFT WIRE ASSEMBLY INSTRUCTIONS

1. Attach the AIRCRAFT WIRE(Q) to a solid structure in accordance to local building code.
2. Position the BRACKET(R) in desired location on ceiling and mark one spot with pencil to drill hole.
Drill 1 hole on the spot and insert ANCHOR(C) into drilled hole.
3. Fix BRACKET(R) with STRENGTHENED SCREW (E) by screwing into ANCHOR(C).
If attach to cement ceiling, use ANCHOR(C) first then screw STRENGTHENED SCREW (E) into the ANCHOR(C).
If attach to wood ceiling, thread STRENGTHENED SCREW (E) directly into ceiling.
4. Remove the COUPLING(S) from the AIRCRAFT WIRE(Q) by loosening the (2) SCREWS(P) before installation.
5. Pass the AIRCRAFT WIRE(Q) through the (2) holes on the BRACKET(R) as the drawing shows.
6. Then pass the AIRCRAFT WIRE(Q) through the (2) holes on the COUPLING(S) and fix with (2) SCREWS(P).
And then tighten (2) SCREWS(P). with a screwdriver.

