

ASSEMBLY AND INSTALLATION INSTRUCTIONS

C0290 / C0291 / C0292 / C0293

WARNING: TO AVOID RISK OF ELECTRICAL SHOCK, BE SURE TO SHUT OFF POWER WHILE INSTALLING OR SERVICING THIS FIXTURE.

NOTE: 1. Before installing, consult local electrical codes for wiring and grounding requirements.
2. Read and save this instructions.

Hardware Package (included):

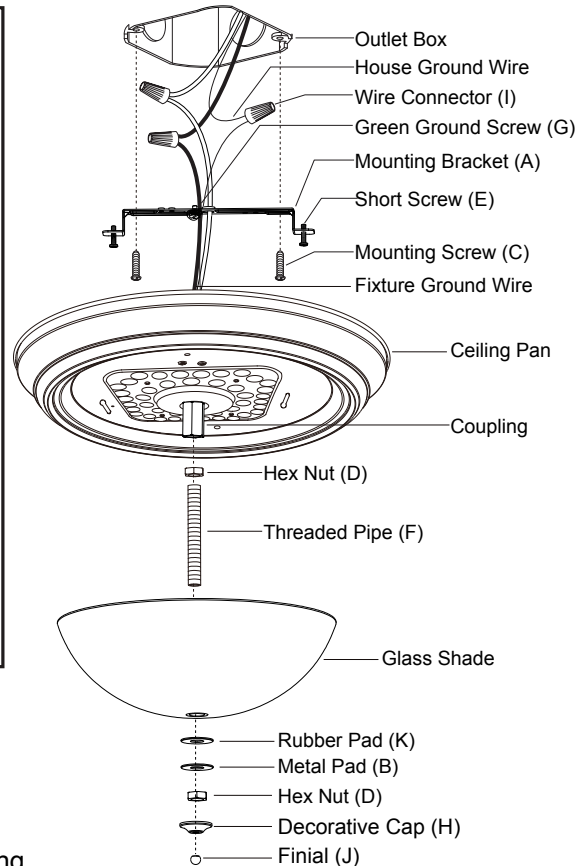
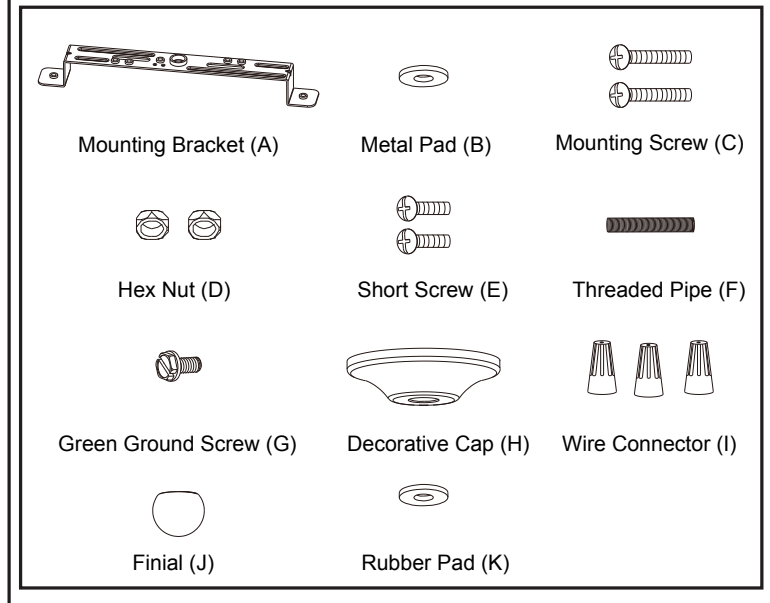

Installation Steps

Turn off the power at fuse or circuit box

- Attach mounting bracket (A) to the outlet box using two mounting screws (C).
- Pull out the source wires from the outlet box. Make wire connections using wire connector (I) as follows:
 - Connect the hot wire (black insulation) from the fixture to the black wire from the power source.
 - Connect the neutral wire (white insulation) from the fixture to the white wire from the power source.
 - Attach the fixture ground wire (bare wire) to the mounting bracket (A) with the green ground screw (G), then connect it to the house ground wire with the wire connector (I).Carefully put all of the wires back into the outlet box.
- Attach the ceiling pan to the mounting bracket (A) by inserting two short screw (E) heads into the keyholes. Rotate the ceiling pan until it is locked into place, then tighten the short screws (E) to secure it.
- Screw the threaded pipe (F) into the coupling, then secure it with a hex nut (D).
Note: Depth of threaded pipe may need to be adjusted to properly fit glass shade, decorative cap and finial.
- Attach the glass shade to the ceiling pan by inserting the threaded pipe (F) through the glass shade, then secure it with a rubber pad (K), metal pad (B) and a hex nut (D).
- Attach the decorative cap (H) end of threaded pipe, then secure it with the finial (J).

Note: This fixture is dimmable with a forward phase electronic dimmer. Dimmers tested to be compatible with this fixture are the Lutron: SCL-153P, DVCL-153P, DVWCL-153P, TGCL-153P. If you are unfamiliar with electrical installations, it is recommended to use a qualified electrician for your installation(s).

The following parts are available for reorder if damaged or missing.

Spare Parts List:

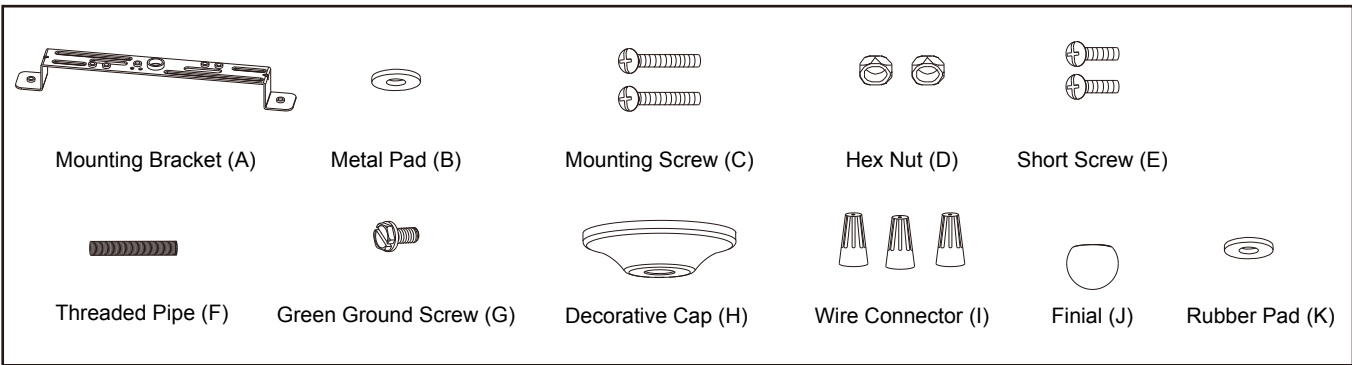

↑ **Mounting Hardware**
 5553MM (1 SET) for C0290
 5555MM (1 SET) for C0292
 5556MM (1 SET) for C0291
 5558MM (1 SET) for C0293

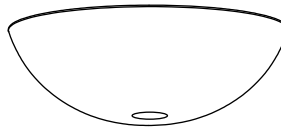

Glass Shade
 9598AL for C0290
 9710AL for C0291 C0292
 9711AL for C0293

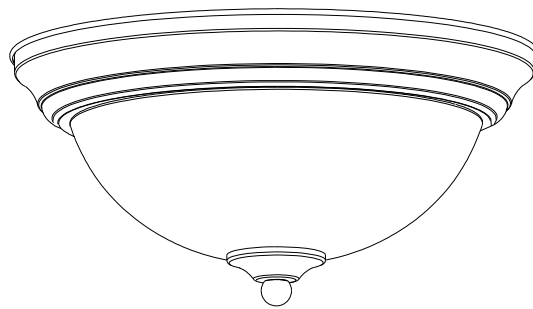

5 Year Limited Warranty

Vaxcel warrants all of our products against defects in workmanship and finishes for one year following the date of shipment.

In addition:

- Any product with an integrated motion sensor or dusk-to-dawn photocell is supported by a 5-year warranty for the functionality of the product.
- Any product with integrated LED modules is covered by a 5-year warranty on the LED functionality.

Exclusions: This warranty does not include the failure of products from extreme acts of nature; environmental conditions not suited for the products intended use; operation in temperatures outside of the range specified in the instruction manual; usage with improper power supply, power surges or dips. For coastal locations, some corrosion is considered normal for the environment.

Vaxcel reserves the right to repair, replace or issue a credit for any properly installed product, provided it is returned per RMA instruction. This warranty is limited to the cost of the product only and does not extend to transportation, installation or replacement costs.

How can warranty service be obtained?
 info@vaxcel.com
 1-800-482-9235