

Collection: STELLA

Product #: IDB0070-24

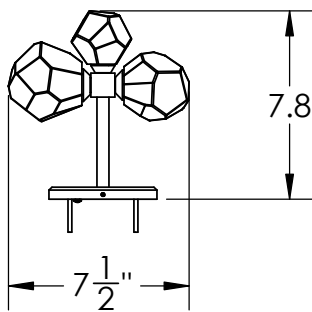

NOTE
 DRIVER TO BE INSTALLED IN JUNCTION BOX.
 MINIMUM SIZE J-BOX REQUIRED IS
 4" L X 4" W X 1.5" D

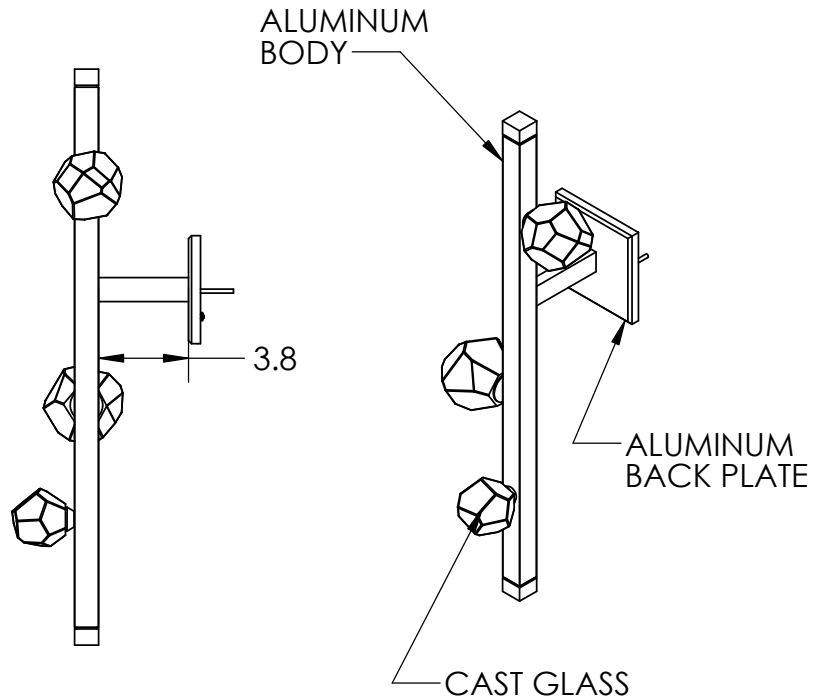
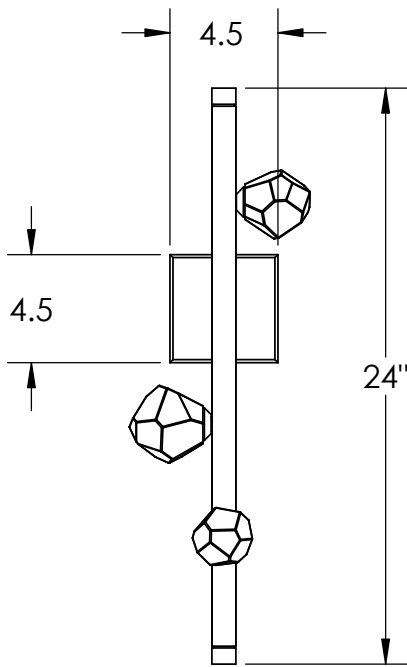
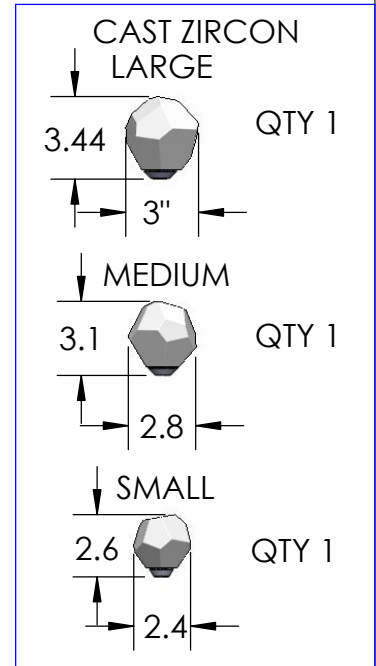

All dimensions are shown in inches unless otherwise stated.
 Visit hammertonstudio.com for product options.

4/20/2022 (B)

Mounting Packet: N	Weight(lbs.): 5	Electrical Type: LED	CCT: 3000K
UL Location: DRY		Elec. Qty: 3	Wattage: 3.7 Voltage: 120
Finish: SEE WEBSITE FOR OPTIONS		Source Lumens:	Ambient: 465
Top Diffuser: N/A		Dimmable:	Forward/Reverse Phase To 1%
Bottom Diffuser: N/A		CRI: 93+	Power Factor: >0.9

Canopy Mounting Detail

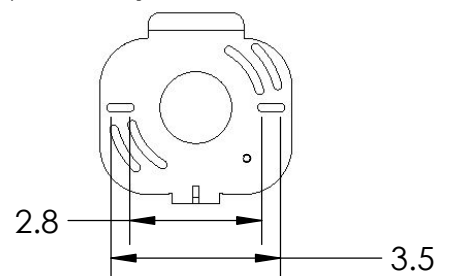

All Hammerton fixtures are handcrafted by artisans. Subtle imperfections reflect the mark of the artisan and should be expected in any handcrafted product. Dimensions may vary up to 7/8".
 © Copyright 2022. All rights in design, detail or invention of this drawing are reserved as the property of Hammerton. Any imitation or adaptation without written consent is strictly prohibited.