

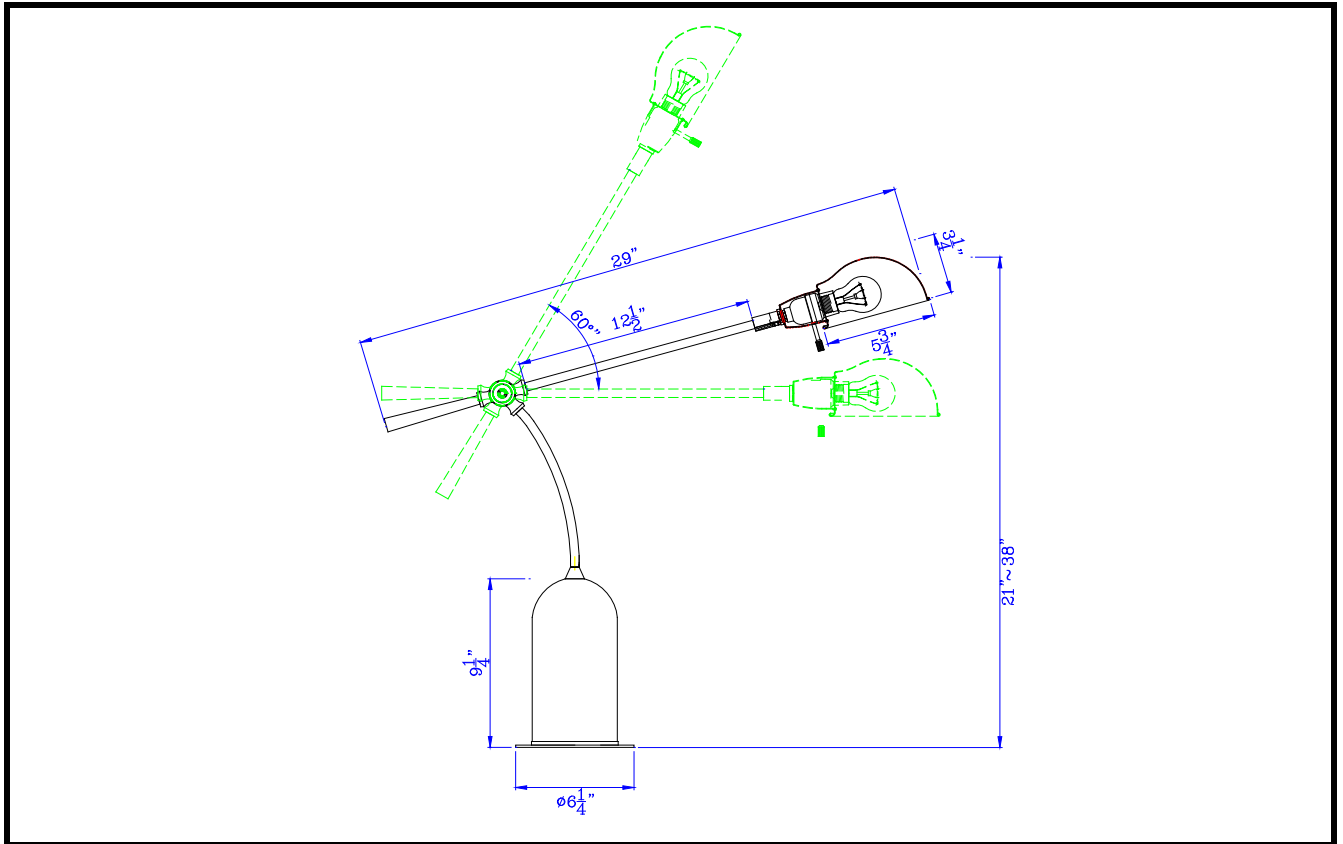

# CAL LIGHTING

3625 E. Philadelphia St. Ontario CA. 91761 • Tel: 909.947.5200 • Fax:  
909.947.5673 • www.calighting.com • service@calighting.com •  
Specifications subject to change without notice

Type: \_\_\_\_\_  
Project: \_\_\_\_\_  
Catalog No.: \_\_\_\_\_  
Lamp/Wattage: \_\_\_\_\_



- Model No:** BO-2890DK  
**Description:** Johnstone metal balanced arm desk lamp with cement base  
**Material:** Metal/Cement  
**Finish :** Black/Cement  
**Height:** 21"~38"  
**Reach/Depth:** 29"  
**Base Width:** Dia.6 1/4"  
**Wattage :** 60W  
**Socket :** Medium Base (E26)  
**Switch:** On/off  
**Bulb:** Incandescent, CFL  
**Wire Length:** 6'  
**Wire Color:** Black  
**Shade No:**  
**Material:** Metal  
**Shade size:** 5 3/4"x 3 1/4"  
**Certificate :** 