

Collection: CARLYLE

Product #: CHB0033-48

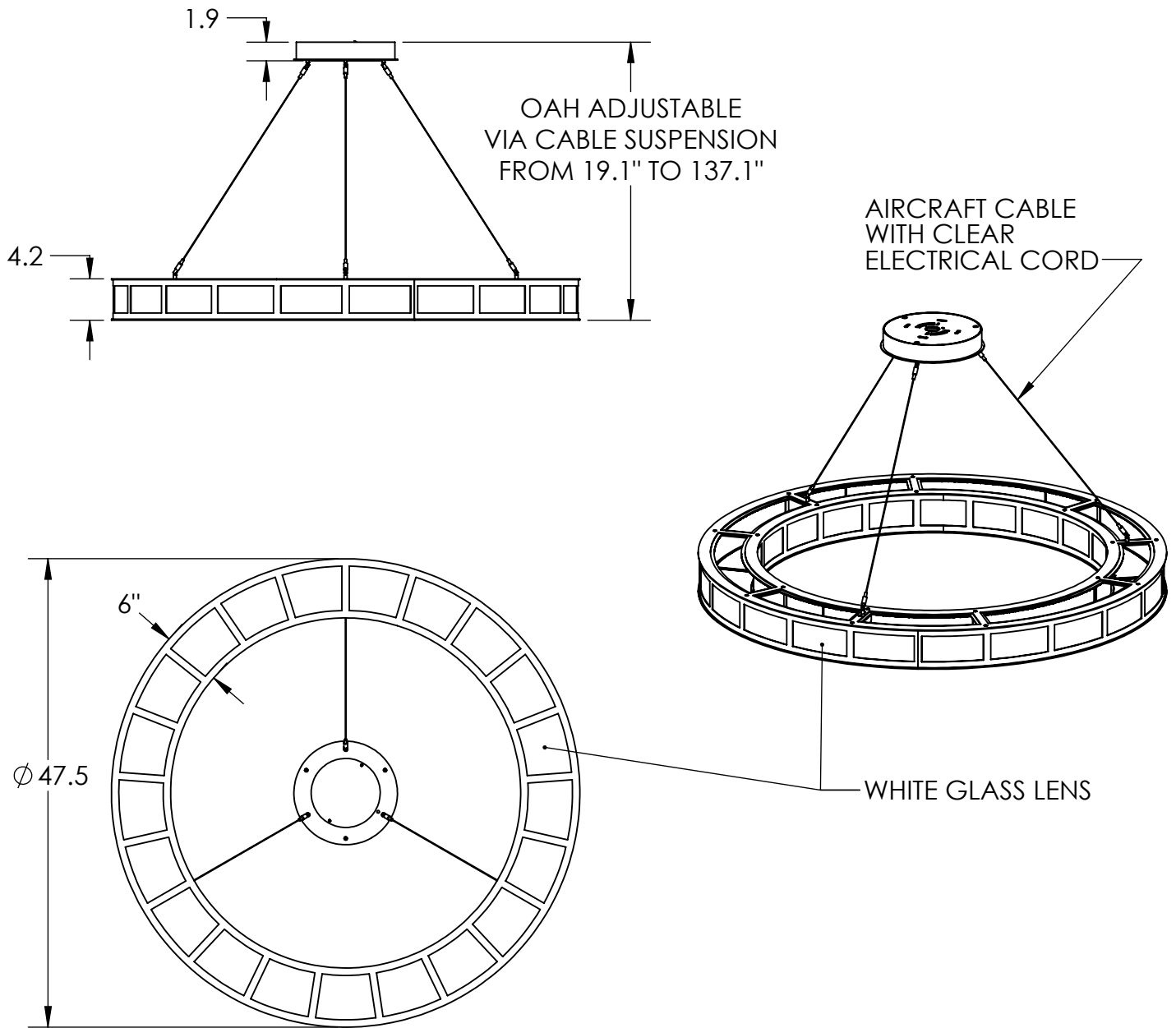

All dimensions are shown in inches unless otherwise stated. Visit hammertonstudio.com for product options.

8/27/2020 (A)

Mounting Packet: S/Z	Weight(lbs.): 70	Electrical Type: LED STRIP	CCT: 3000 K
UL Location: DRY		Wattage: 50	Voltage: 120
Finish: SEE WEBSITE FOR OPTIONS		Source Lumens:	Ambient: 3524
Top Diffuser: OPEN		Dimmable: Forward/Reverse Phase To 1%	
Bottom Diffuser: CLOSED, SAME AS LENS	CRI: 90+	Power Factor: >0.9	

All Hammerton fixtures are handcrafted by artisans. Subtle imperfections reflect the mark of the artisan and should be expected in any handcrafted product. Dimensions may vary up to 7/8".

© Copyright 2020. All rights in design, detail or invention of this drawing are reserved as the property of Hammerton. Any imitation or adaptation without written consent is strictly prohibited.

Canopy Mounting Detail

