

ARTERIOS

ORLANDO CHANDELIER

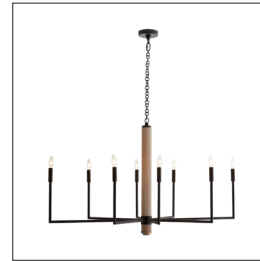
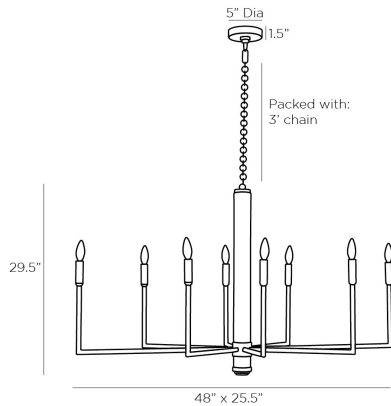

84068

H: 32 IN, W: 48 IN, D: 25.5 IN

Blackened Iron

Contract Suitable As Is

The Orlando finds balance in a traditional shape and industrial materials. The elongated, pseudo linear candelabra silhouette is crafted from blackened iron and is introduced by a natural driftwood column. Fitted with eight lights for incredible brilliance. Finish will vary. Additional chain available (CHN-263). Damp-rated, although limited covered outdoor areas may affect finish.

APPEARANCE

Material	Driftwood, Iron
Finish	Blackened Iron, Natural
Finish Will Vary	true
Top Coat/Sealant	true

DIMENSIONS

Chandelier	H: 29.5 IN, W: 48 IN, D: 25.5 IN
Minimum Hanging Height	32 IN
Maximum Hanging Height	67 IN
Canopy	H: 1.5 IN, Dia: 5.00 IN

WIRING

Rating	Damp
Certification Note	PENDING REVIEW
Suggested Bulb Type	B10
Cord	10 FT, Clear/Silver, SVT
Socket	8, Type B - E12
Photographed Bulb	Clear Straight Tip Candelabra Bulb
Maximum Watt	40
Voltage	110-120 V

CERTIFICATIONS

Certifications	Mexico United States, Canada
----------------	---------------------------------

COMPLIANCY

UL/ETL	Yes
RoHS	true

SHIPPING

Shipping Requirements	TruckShip
Product Weight	20 LBS
Gross Weight 1	42.9 LBS
Shipping Box 1	H: 30.75 IN, L: 51.2 IN, W: 28.35 IN
Shipping Box 2	H: 0 IN, L: 0 IN, W: 0 IN
Shipping Box 3	H: 0

REPLACEMENT PARTS

Replacement Part 1	CHN-263
Replacement Part 1 Dim	3'
Replacement Part 2	CANOPY-576
Replacement Part 2 Dim	1.5" x 5" Dia

CONTRACT

Contract Suitable	true
-------------------	------