

Collection: GEM

Product #: IDB0039-18

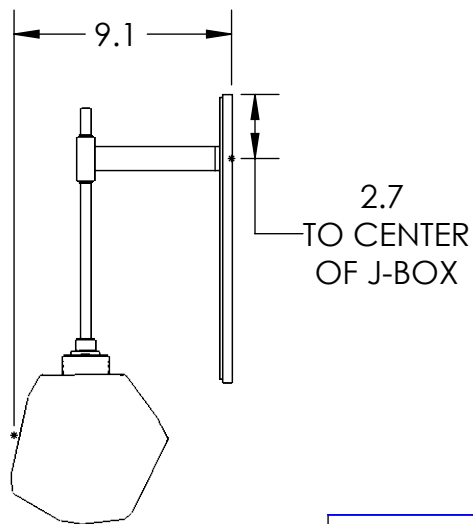

****NOTE****
 DRIVER TO BE INSTALLED IN JUNCTION BOX.
 MINIMUM SIZE J-BOX REQUIRED IS
 4" L X 4" W X 1.5" D

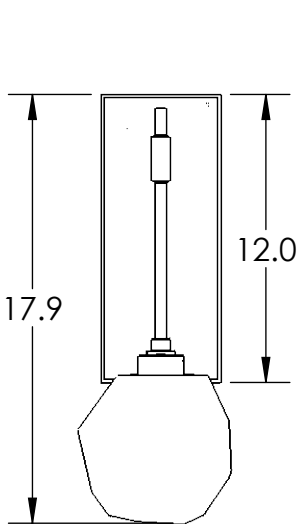
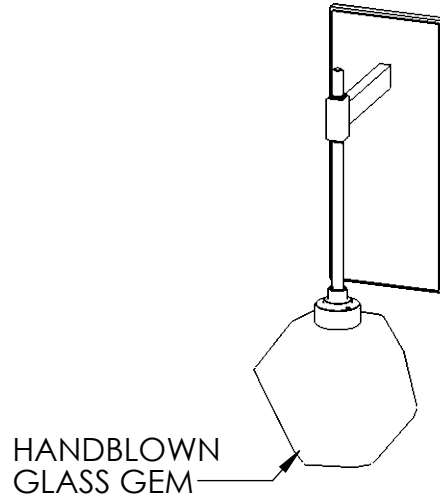
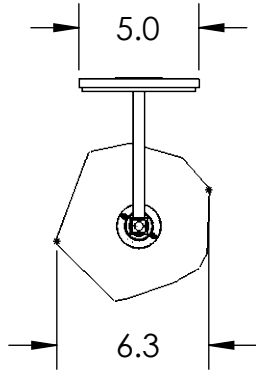
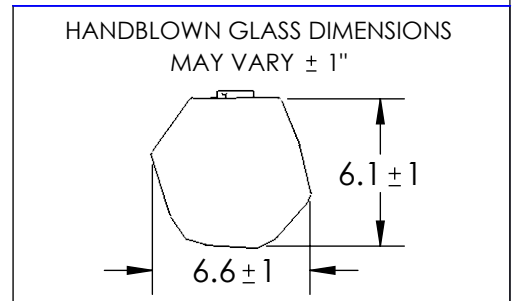

All dimensions are shown in inches unless otherwise stated.
 Visit hammeronstudio.com for product options.

3/23/2022 (B)

Mounting Packet: N	Weight(lbs.): 6	Electrical Type: LED	CCT: 2700/3000 K
UL Location: DRY		Elec. Qty: 1	Wattage: 5.2 Voltage: 120
Finish: SEE WEBSITE FOR OPTIONS		Source Lumens: UP: N/A	Down: 420
Top Diffuser: N/A		Dimmable: Forward/Reverse Phase To 1%	
Bottom Diffuser: CLOSED GLASS		CRI: 93+	Power Factor: >0.9

Canopy Mounting Detail

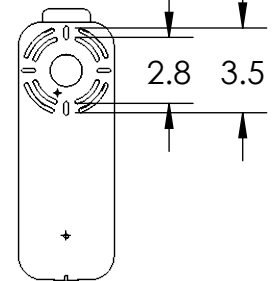

MOUNTS DIRECTLY TO J-BOX

All Hammerton fixtures are handcrafted by artisans. Subtle imperfections reflect the mark of the artisan and should be expected in any handcrafted product. Dimensions may vary up to 7/8".

© Copyright 2022. All rights in design, detail or invention of this drawing are reserved as the property of Hammerton. Any imitation or adaptation without written consent is strictly prohibited.