

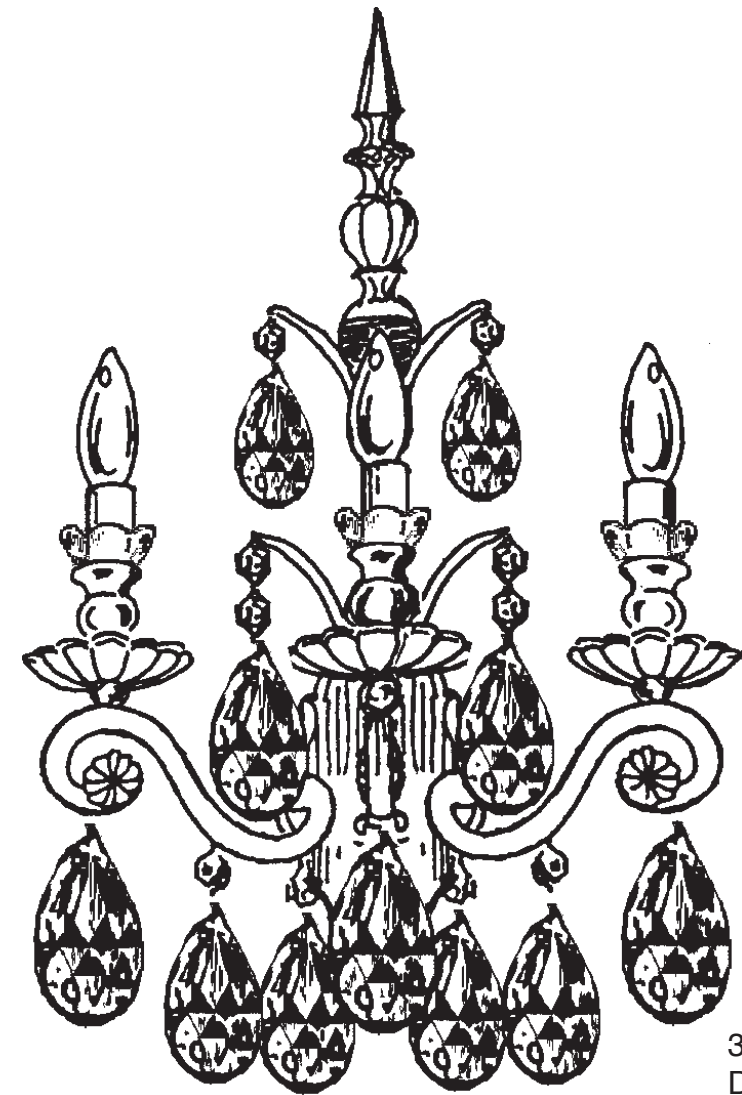

SCHONBEK®

RENAISSANCE 3762- _____



3 Lights
Diameter: 15"
Body Length: 22"
Extension: 8"
Hanging Weight: 8 lbs.

THIS DESIGN IS THE PROPRIETARY
TRADE DRESS/TRADEMARK OF
SWAROVSKILIGHTING, LTD.



SCHONBEK®

MAX 60 W		110-120 V						

SCHONBEK® is a member of the Swarovski group.

All electrical components must be installed by a licensed electrician in accordance with the National Electric Code and the appropriate local electrical codes.

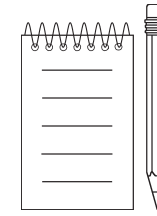
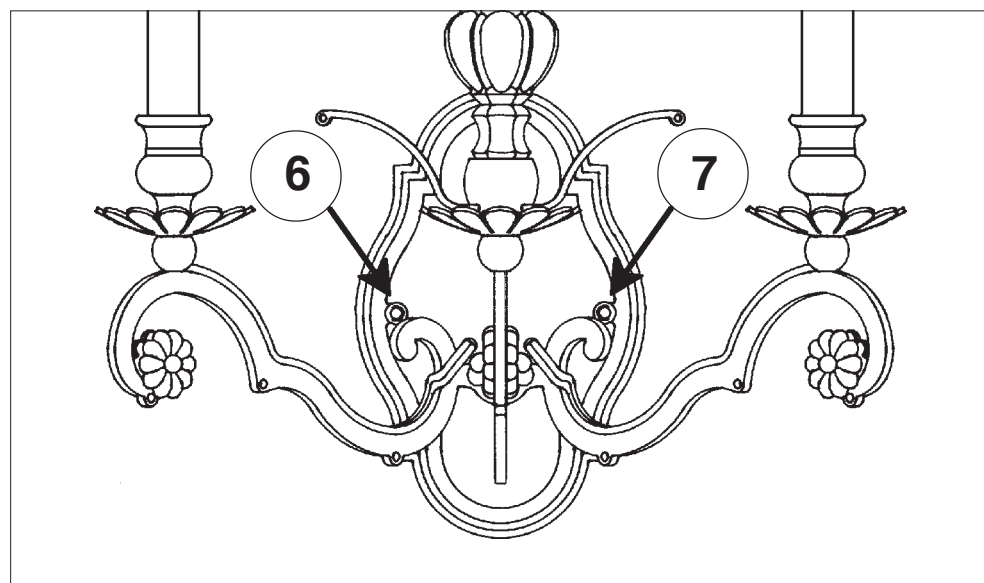
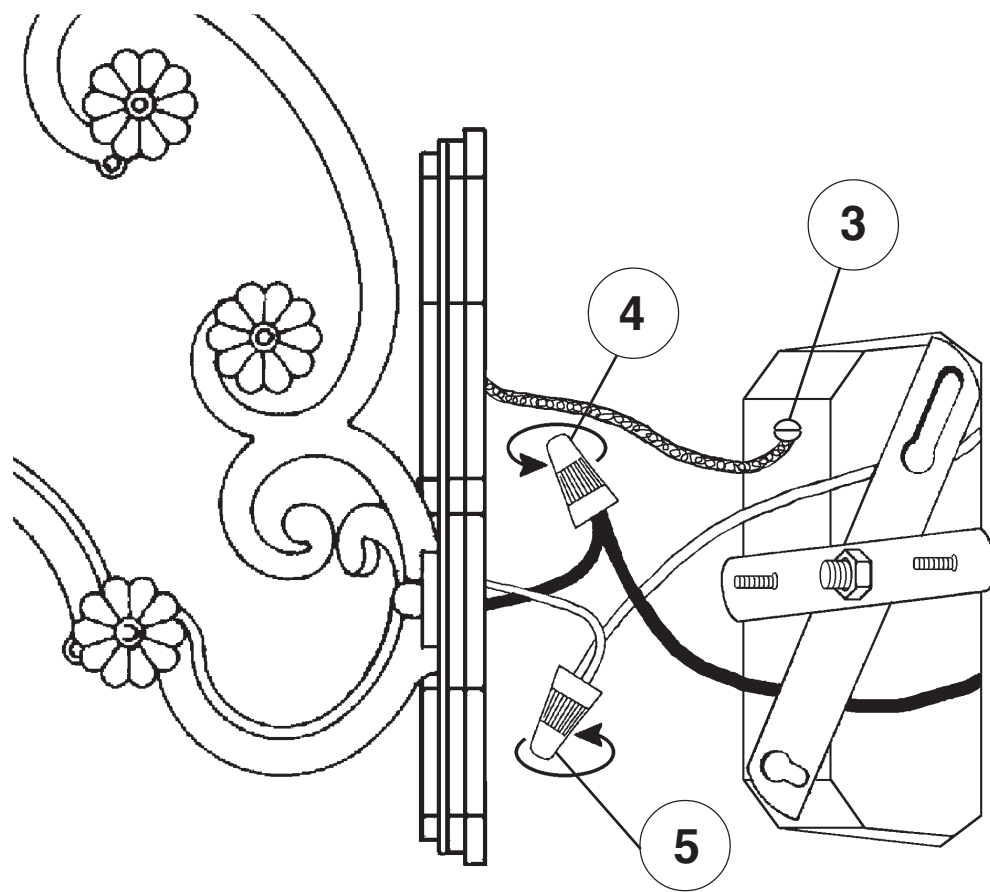
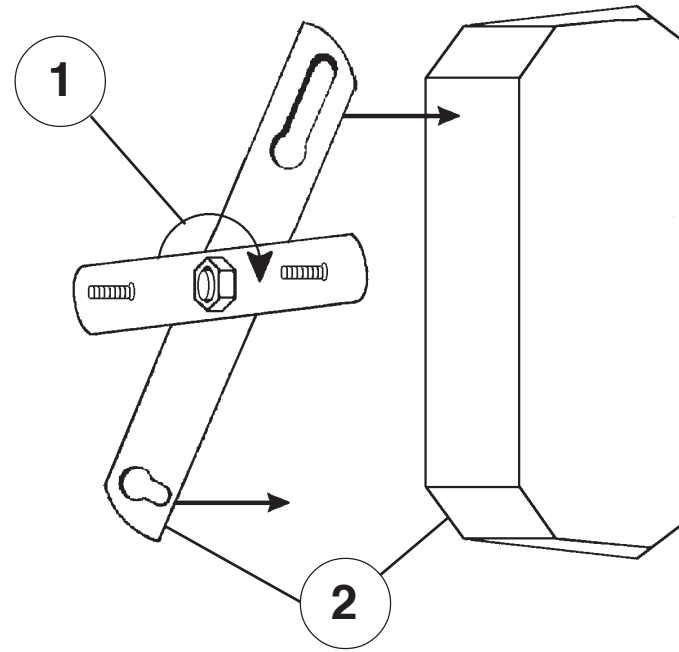

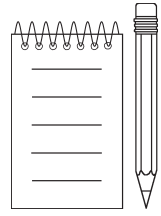

SET #1

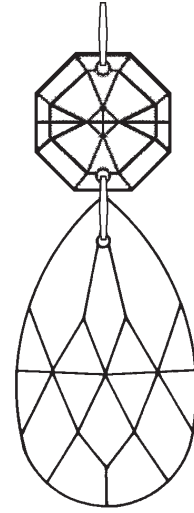

N4044-**
2"
50mm

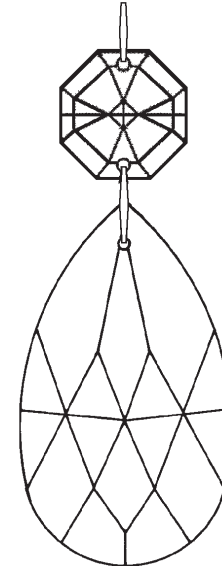

N4003-**
2-1/2"
63mm

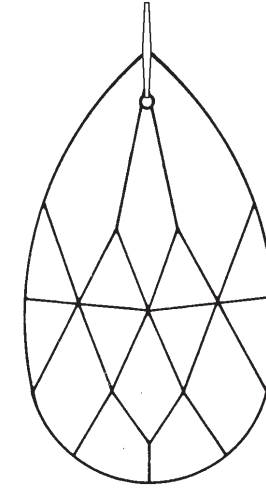

N4004-**
3"
76mm

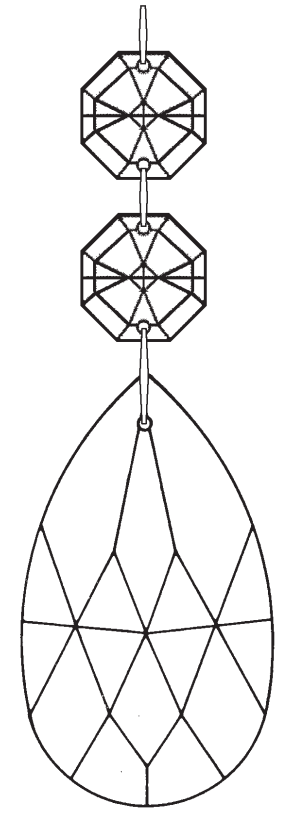

N4010-**
3"
76mm

SET #2

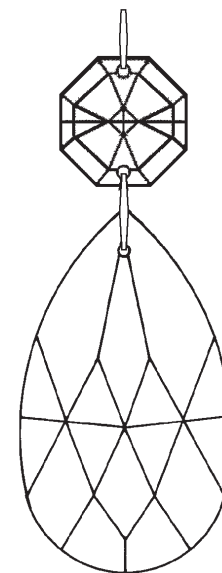

N4003-**
2-1/2"
63mm

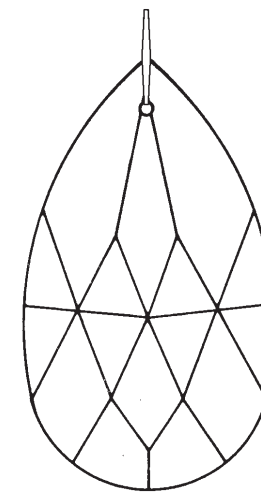

N4004-**
3"
76mm

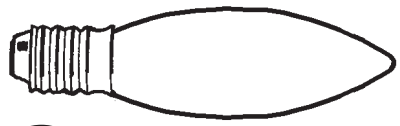

9 3 - B10
60 Watts Max
25 Watts Recommend

Crystal Set #2 in Black

Crystal Set #1 in Black

