

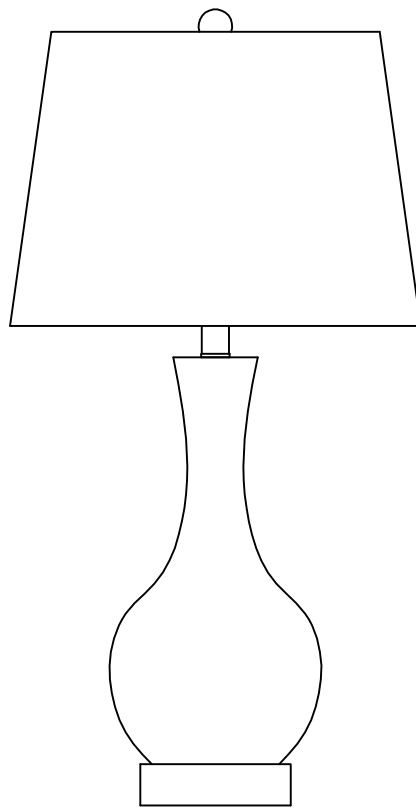

ALL • TOGETHER • BETTER

USE AND CARE GUIDE

TABLE LAMP-K/D NECK-150W



Above image represents many lamps,
your lamp may vary in style.

Questions, problems, missing parts? Before returning to the store,
call Kenroy Home Customer Service
8 a.m.-6 p.m., EST, Monday-Friday

904-642-4340

THANK YOU

We appreciate the trust and confidence you have placed in Kenroy Home through the purchase of this lamp.
We strive to continually create quality products designed to enhance your home.
Thank you for choosing us!

Table of Contents

Safety Information	2
Warranty	2
Pre-Installation	3
Planning Installation	3
Package Contents	3
Assembly	4, 5, 6
Care and Cleaning	7
Troubleshooting	7

Safety Information

Consult a qualified electrician with any electrical questions you may have.



IMPORTANT: Inspect the wire insulation for any cuts, abrasions, or exposed copper that may have occurred during shipping. If there is a defect in the wire, do not continue the assembly process. Please call our Customer Service Team at 904-642-4340.

Warranty

1-YEAR LIMITED WARRANTY

WHAT IS COVERED

The manufacturer warrants this lamp to be free from defects in the materials and workmanship for a period of one (1) year from date of purchase. This warranty applies only to the original consumer purchaser and only to products used in normal use. If this product is found to be defective, the manufacturer's only obligation, and your exclusive remedy, is the repair or replacement of the product at the manufacturer's discretion, provided that the product has not been damaged through misuse, abuse, accident, modifications, alterations, neglect or mishandling. This warranty shall not apply to any product that is found to have been improperly installed, assembled, or used in any way not in accordance with the instructions supplied with the product. This warranty shall not apply to a failure of the product as a result of an accident, misuse, abuse, negligence, alteration, faulty installation, or any other failure not relating to faulty material or workmanship.

WHAT IS NOT COVERED

This warranty shall not apply to the finish on any portion of the product due to weathering, as this is considered normal wear. The manufacturer does not warrant and specifically disclaims any warranty, whether expressed or implied, other than the warranty contained herein. The manufacturer specifically disclaims any liability and shall not be liable for any consequential or incidental loss or damage, including but not limited to, any labor or expense costs involved in the replacement or repair of the product.

Contact the Customer Service Team at 904-642-4340.

Pre-Installation

PLANNING INSTALLATION

Read all instructions before assembly.

To avoid damaging this product, assemble it on a soft, non-abrasive surface such as carpet or cardboard. Inspect each part for defects that may have occurred during shipping.

Keep your receipt and these instructions for proof of purchase.

 **NOTE:** This lamp requires the use of one 120V, 60Hz, 150-Watt max, medium-base type A 3-way bulb (not included). Do not exceed the recommended wattage.

PACKAGE CONTENTS

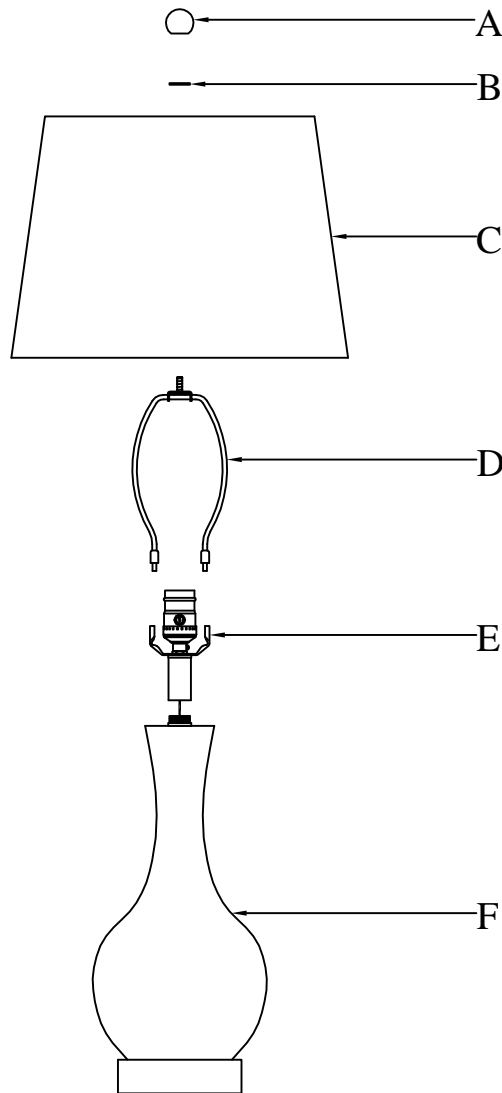

Part	Description	Quantity
A	Finial	1
B	Rubber washer	1
C	Shade	1
D	Harp	1
E	Socket assembly	1
F	Lamp body	1

Assembly instructions

1. Unpack the lamp

- Carefully organize and place all parts on a smooth, flat surface. line up all of the parts according to the assembly diagram.

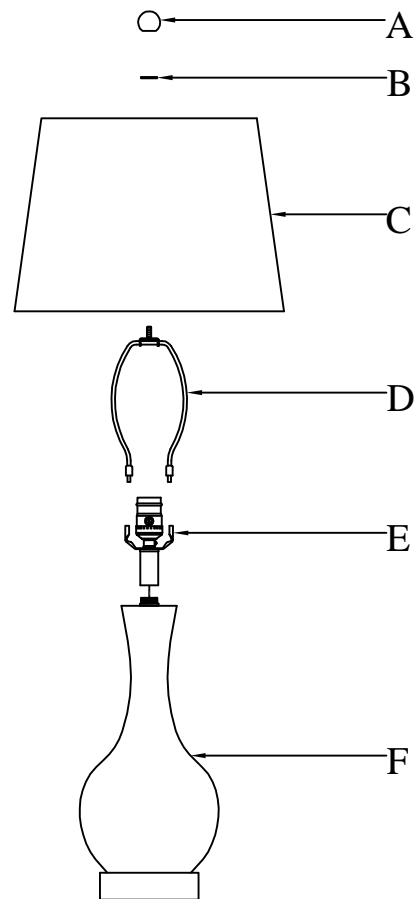

2. Assemble the socket assembly

- Pull the excess power cord through base.
- Screw the socket assembly (E) to top of the lamp body (F).

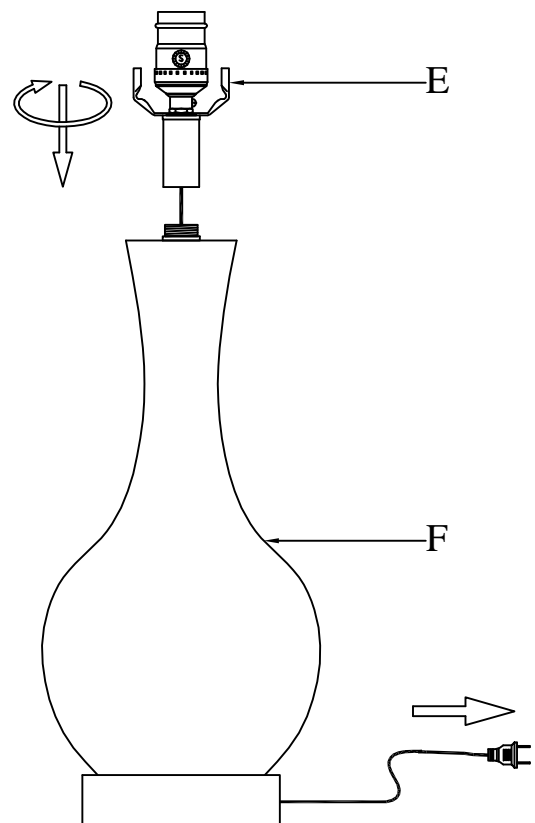

Assembly instructions (continued)

3. Assemble the harp

- Squeeze legs of the harp (D) together and insert the two ends between the prongs of the harp holder.

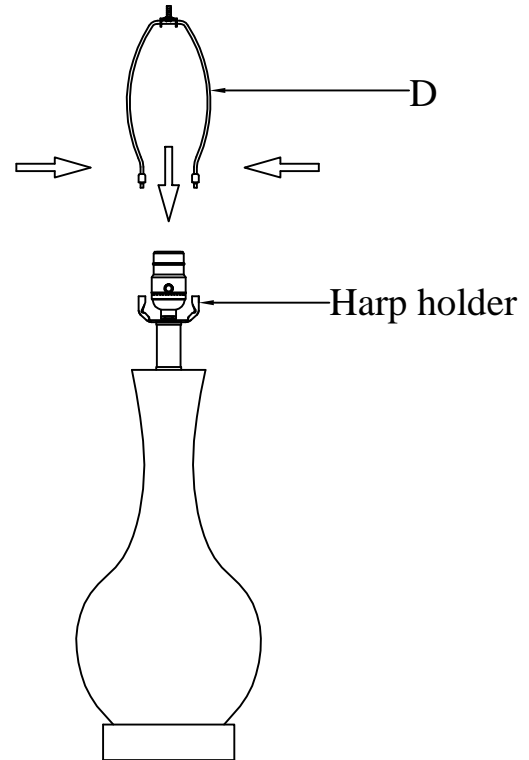

4. Assemble the shade

- Place the shade (C) onto the harp (D).
- Secure the shade (C) to harp with rubber washer (B) and finial (A).

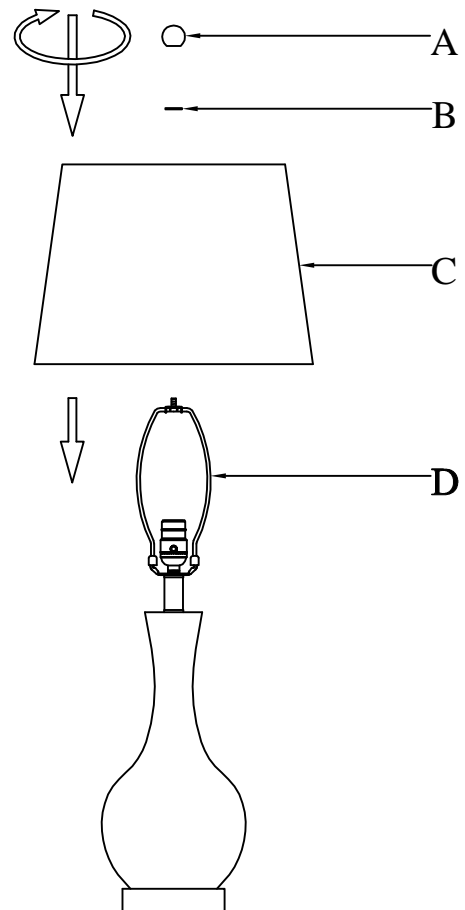

Assembly instructions (continued)

5. Install the bulb

- Prior to installing the bulb, inspect socket for silica packet. If packet is present, then remove and throw away. Do not expose it to children or pets.
- Install one 120V, 60Hz, 150-watt max. medium-base type A 3-way bulb (not included) into the socket of the light lamp.

NOTES: Make sure a 3-way bulb is being used and that the bulb is fully screwed into the base of the socket. this may require an extra turn of the bulb.

- Plug cord into an outlet and turn on at the switch.

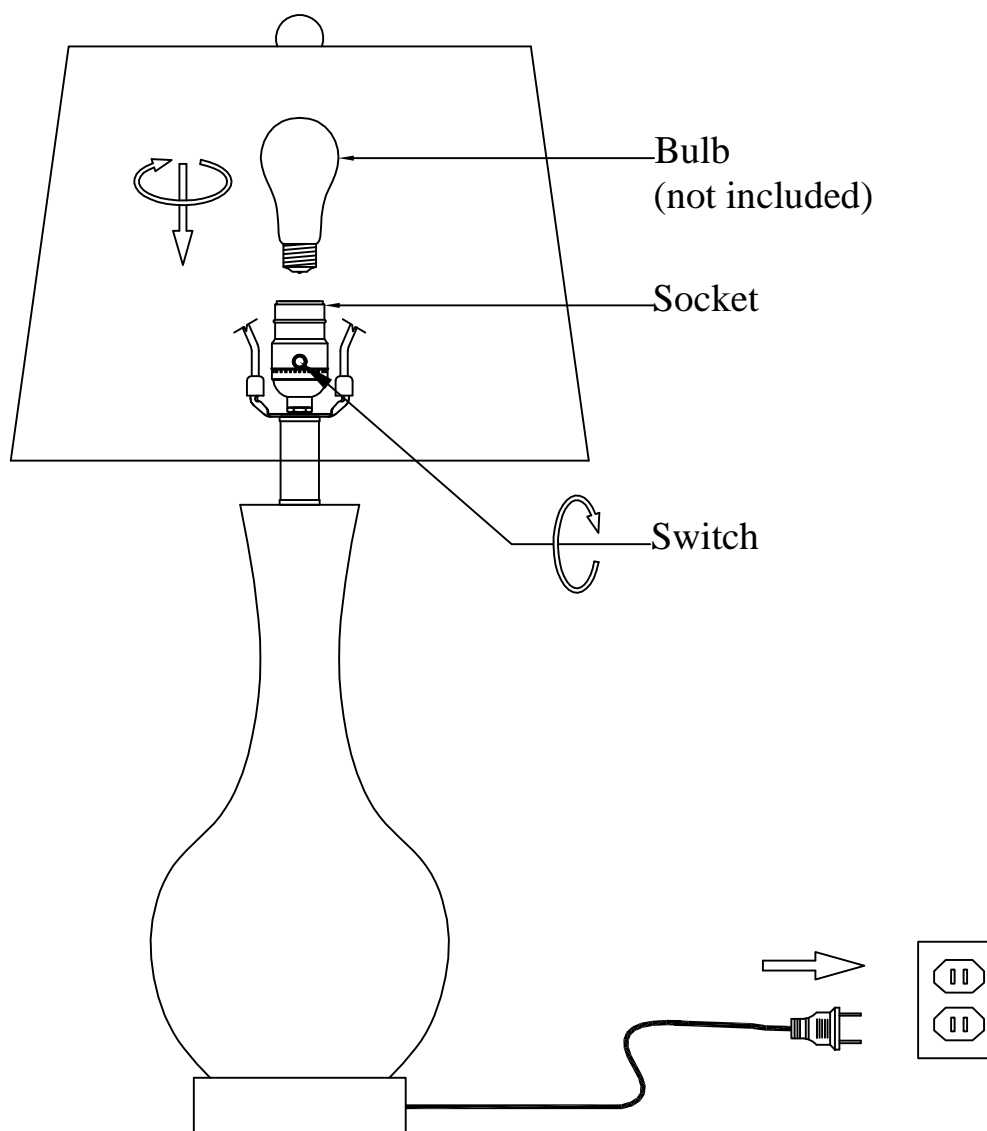

Important safety instructions

This portable lamp has a polarized plug (one blade is wider than the other) as a feature to reduce the risk of electric shock. This plug will fit in a polarized outlet only one way. If the plug does not fit fully in the outlet, reverse the plug. If it still does not fit, contact a qualified electrician. never use with an extension cord unless plug can be fully inserted. Do not alter the plug.

Care and Cleaning

Clean the lamp with a soft, dry cloth. Do not use any cleaners with chemicals, solvents, or harsh abrasives.

Troubleshooting

Problem	Possible Cause	Solution
The bulb will not light.	<input type="checkbox"/> The bulb is burned out.	<input type="checkbox"/> Replace the light bulb.
	<input type="checkbox"/> The power is off.	<input type="checkbox"/> Ensure that the power supply is turned on.
	<input type="checkbox"/> Did not insert plug into power outlet.	<input type="checkbox"/> Ensure that the plug is fully and properly inserted into the power outlet.
	<input type="checkbox"/> The circuit breaker is off.	<input type="checkbox"/> Ensure that the circuit breaker is set in the on position.
The fuse blows or a circuit breaker trips when the light is turned on.	<input type="checkbox"/> There is an exposed wire. <input type="checkbox"/> There are too many items on one circuit.	<input type="checkbox"/> Discontinue use of the lamp. <input type="checkbox"/> Contact a qualified electrician or call the Customer Service Team at 904-642-4340. <input type="checkbox"/> Unplug other items on the circuit.



ALL • TOGETHER • BETTER



www.kenroyhome.com

CUSTOMER SUPPORT TEAM

For any additional questions or concerns please contact our Customer Support Team:

 **904-642-4340**

 **@KenroyHome**

 **customerorders@kenroyhome.com**