

Collection: COSMOS (NEBULA)

Product #: CHB0065-08

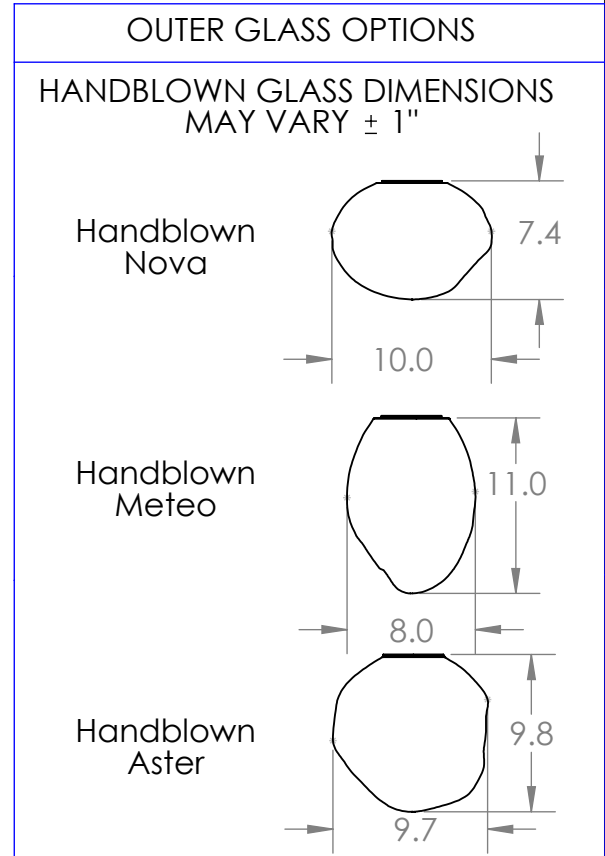
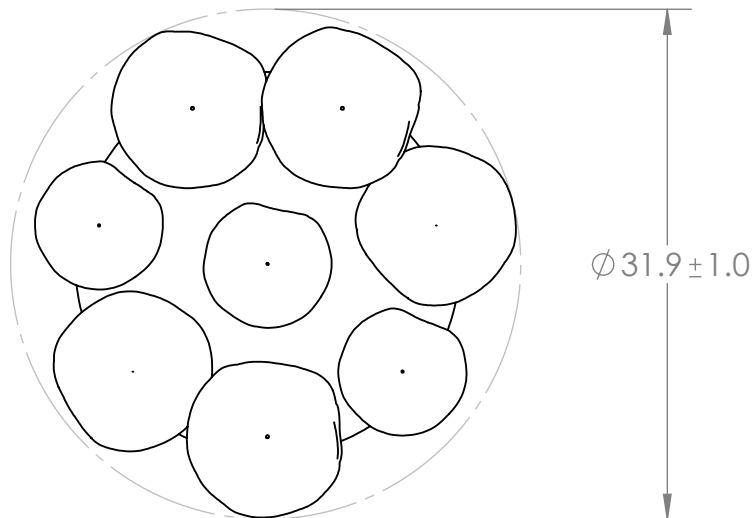
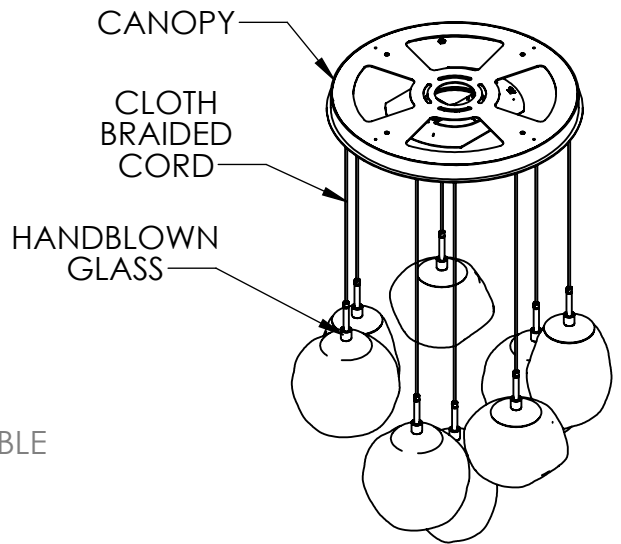
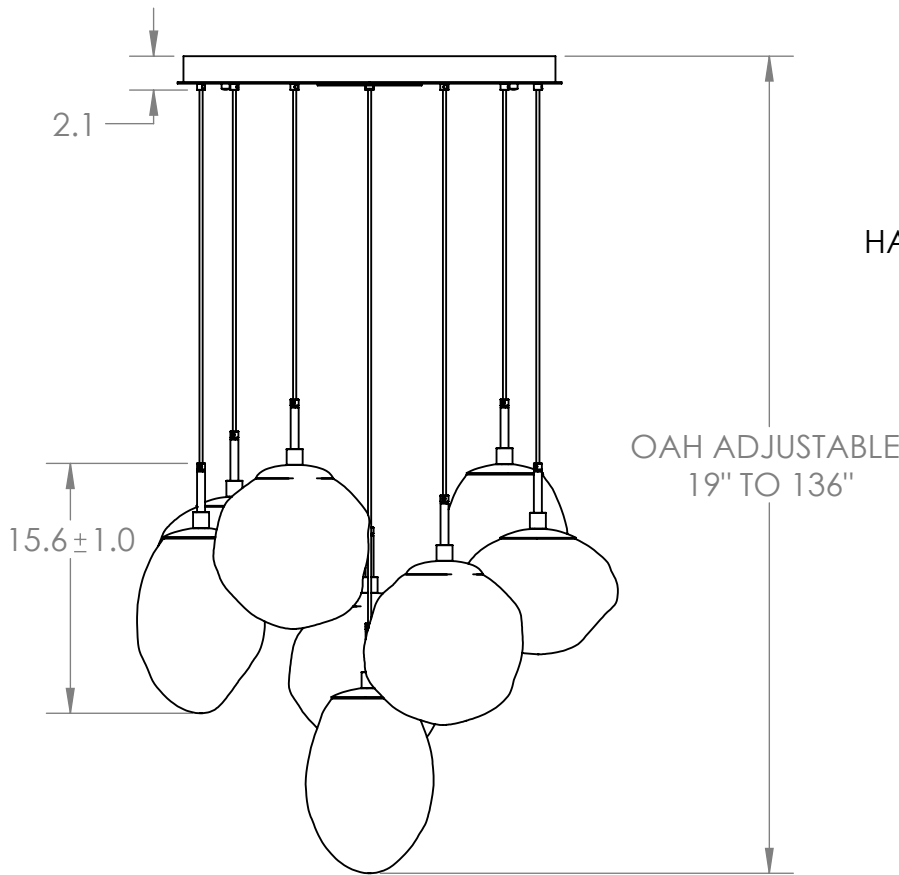

Bulbs Not Included All dimensions are shown in inches unless otherwise stated. Visit hammertonstudio.com for product options and specifications. 4/12/2022 (A)

Mounting Packet: R	Electrical Type: INCANDESCENT
Approximate lbs.: 76	Bulb Qty: 8 Bulb Type: ST19
Finish: SEE WEBSITE FOR OPTIONS	Wattage: 40 Voltage: 120
Top Diffuser: N/A	Socket Type: E26
Bottom Diffuser: CLOSED GLASS	UL Location: DRY

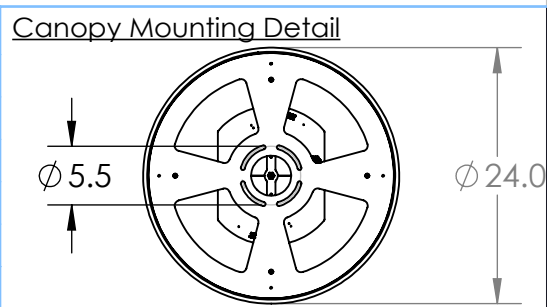

All fixtures created by Hammerton are handcrafted by artisans. Dimensions may vary up to 7/8".
 © Copyright 2022. All rights in design, detail or invention of this drawing are reserved as the property of Hammerton. Any imitation or adaptation without written consent is strictly prohibited.