

INSTALLATION INSTRUCTIONS

Recessed Grid Channel

S2CG*02-FE, S2CG*04-FE, S2CG*05, S2CG*06, S2CG*06-FE, S2CG*08, S2CG*08-FE



CAUTION: TO PREVENT ELECTRICAL SHOCK, ENSURE ELECTRICITY HAS BEEN TURNED OFF AT THE CIRCUIT BREAKER BEFORE BEGINNING.

- Read all instructions before installing.
- System is intended for installation by a licensed electrician in accordance with the National Electrical Code (NEC) and local regulations.
- Retain installation instructions for future reference.
- VENTRIX fixtures and channels feature separate data and power conductor systems. During installation and use, do not short the data or power conductors together by any means or damage may occur.

WARNING: All parts must be used as indicated in these instructions. This product is designed for use only with the supplied parts and/or accessories designated for use by WAC Lighting. Substitution of parts or accessories not designated for use with this product by WAC Lighting could result in personal injury or property damage, and will void the warranty. Contact an authorized dealer or the manufacturer if any parts are damaged or missing.

MISE EN GARDE: POUR ÉVITER TOUT CHOC ÉLECTRIQUE, ASSUREZ-VOUS QUE LE DISJONCTEUR SOIT MIS HORS TENSION AVANT DE COMMENCER.

- Lisez toutes les instructions avant l'installation.
- Le système doit être installé par un électricien licencié conformément au code national de l'électricité (NEC), et également aux règlements locaux.
- Lors de la manipulation du luminaire, n'appuyez pas sur les LED. Tenez-le uniquement par la base.

ATTENTION: Toutes les pièces doivent être utilisées comme indiqué dans ces instructions. Ce produit est conçu pour être utilisé seulement avec les pièces et/ou accessoires fournis pour être utilisés avec les produits WAC Lighting. Remplacer des pièces ou accessoires non conçus pour ce produit WAC Lighting pourrait causer des dommages corporels ou matériels et pourrait également causer l'annulation de la garantie. Veuillez contacter un revendeur autorisé ou le fabricant si des pièces manquent ou sont endommagées.

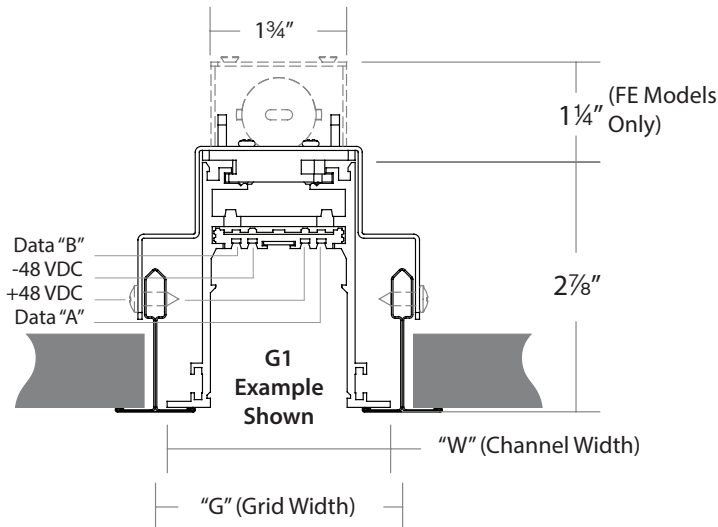

VENTRIX Channels are intended for use with WAC Lighting's VENTRIX system. Reference specific VENTRIX components instructions for complete system installation.

SPECIFICATIONS	
Input:	48 VDC (Max 12.5A), Data via VENTRIX CPU
Installation:	Dry Location, Suspended Ceiling Systems
*Do not install concealed or extended through building walls.	

CHANNEL DIMENSIONS		
Grid Type	"W" Channel Width	"G" Grid Width
G1	2 5/8"	2 7/8"
G2	2 1/4"	2 7/8"
G3	2 5/8"	2 7/8"
G4	2 1/4"	2 1/2"
G5	2 1/4"	2 1/2"

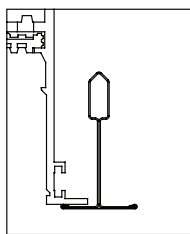

G1
15/16"
Lay-In Grid

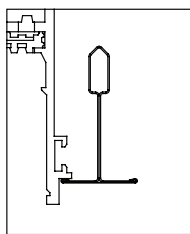

G2
15/16"
Tegular Grid

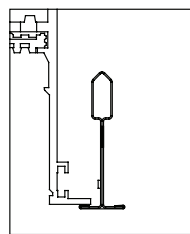

G3
9/16"
Lay-In Grid

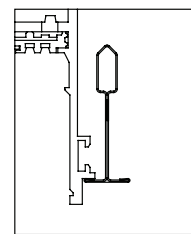

G4
9/16"
Tegular Grid

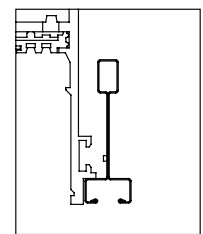

G5
9/16"
Slot Grid

wacighting.com

Phone (800) 526.2588

Fax (800) 526.2585

Headquarters, East Manufacturing Facility

44 Harbor Park Drive

Port Washington, NY 11050

South East Manufacturing Facility

1600 Distribution Ct

Lithia Springs, GA 30122

Central Manufacturing Facility

1700 South J Elmer Freeway, Ste 100

Cedar Hill, TX 75104

West Manufacturing Facility

1750 S Archibald Ave

Ontario, CA 91761

INSTALLATION INSTRUCTIONS

Recessed Grid Channel

S2CG*02-FE, S2CG*04-FE, S2CG*05, S2CG*06, S2CG*06-FE, S2CG*08, S2CG*08-FE



VENTRIX RECESSED GRID CHANNEL MOUNTING AND RUN CONFIGURATION

CHOOSE YOUR CHANNELS AND CONNECTORS

- Power feed from feed end channel or I connector to energize your run.
- Support VENTRIX with tie wires, or 1/4"-20 tie rod (by others) using S2CR-CLIP-BK (sold separately). Minimum two supports per channel segment.
- For patterns, choose L, and I connectors (sold separately) or consult factory.

NOTE: VENTRIX is field cut at end of run or between channels using below bus bar connector S2C-IB. For custom length channels, consult factory.

CHOOSE YOUR ELEMENTS

- Refer to element specifications to appropriately select elements.
- **NOTE:** Grid channel lengths are shorter than nominal, pay attention when selecting element lengths.
- Total the wattage of the system.

CHOOSE YOUR CONNECTED POWER UNIT (CPU)

- Select remote mount CPU.
- Select appropriate wattage based on total system wattage.

NOTE: Recommended sizing up as feasible for increased system capability.

ACCESSORIZE

- Add channel covers, lenses, or glare control accessories as desired.

VENTRIX RECESSED GRID RUN CONFIGURATION CHART

<i>Distance Between Grid Centers (ft)</i>	<i>VENTRIX Channel Components</i>	<i>Distance Between Grid Centers (ft)</i>	<i>VENTRIX Channel Components</i>
2	2' FE	21	8' FE + 8' EXT + 5' EXT
3	Field cut 4' FE or Custom order from factory	22	8' FE + 8' EXT + 6' EXT
4	4' FE	23	8' FE + 5' EXT + 5' EXT + 5' EXT
5	Field cut 6' FE or Custom order from factory	24	8' FE + 8' EXT + 8' EXT
6	6' FE	25	8' FE + 6' EXT + 6' EXT + 5' EXT
7	Field cut 8' FE or Custom order from factory	26	8' FE + 6' EXT + 6' EXT + 6' EXT
8	8' FE	27	8' FE + 8' EXT + 6' EXT + 5' EXT
9	4' FE + 5' EXT	28	8' FE + 8' EXT + 6' EXT + 6' EXT
10	4' FE + 6' EXT	29	8' FE + 8' EXT + 8' EXT + 5' EXT
11	6' FE + 5' EXT	30	8' FE + 8' EXT + 8' EXT + 6' EXT
12	6' FE + 6' EXT	31	8' FE + 6' EXT + 6' EXT + 6' EXT + 5' EXT
13	8' FE + 5' EXT	32	8' FE + 8' EXT + 8' EXT + 8' EXT
14	8' FE + 6' EXT	33	8' FE + 8' EXT + 6' EXT + 6' EXT + 5' EXT
15	4' FE + 6' EXT + 5' EXT	34	8' FE + 8' EXT + 6' EXT + 6' EXT + 6' EXT
16	8' FE + 8' EXT	35	8' FE + 8' EXT + 8' EXT + 6' EXT + 5' EXT
17	6' FE + 6' EXT + 5' EXT	36	8' FE + 8' EXT + 8' EXT + 6' EXT + 6' EXT
18	8' FE + 5' EXT + 5' EXT	37	8' FE + 8' EXT + 8' EXT + 8' EXT + 5' EXT
19	8' FE + 6' EXT + 5' EXT	38	8' FE + 8' EXT + 8' EXT + 8' EXT + 6' EXT
20	8' FE + 6' EXT + 6' EXT	39	8' FE + 8' EXT + 6' EXT + 6' EXT + 6' EXT + 5' EXT
		40	8' FE + 8' EXT + 8' EXT + 8' EXT + 8' EXT

NOTE: Channel I connectors and accessories not shown in above chart and sold separately.

NOTE: If a run requires multiple CPU's, options are to use recessed I connector with feed in conjunction with dead I connector or custom order from factory. Consult factory for configuration of runs longer than 40 ft.

wacighting.com	Headquarters, East Manufacturing Facility	South East Manufacturing Facility	Central Manufacturing Facility	West Manufacturing Facility
Phone (800) 526.2588	44 Harbor Park Drive	1600 Distribution Ct	1700 South J Elmer Freeway, Ste 100	1750 S Archibald Ave
Fax (800) 526.2585	Port Washington, NY 11050	Lithia Springs, GA 30122	Cedar Hill, TX 75104	Ontario, CA 91761

INSTALLATION INSTRUCTIONS

Recessed Grid Channel

S2CG*02-FE, S2CG*04-FE, S2CG*05, S2CG*06, S2CG*06-FE, S2CG*08, S2CG*08-FE



FIG. 1. Individual Channel and Grid Dimensions

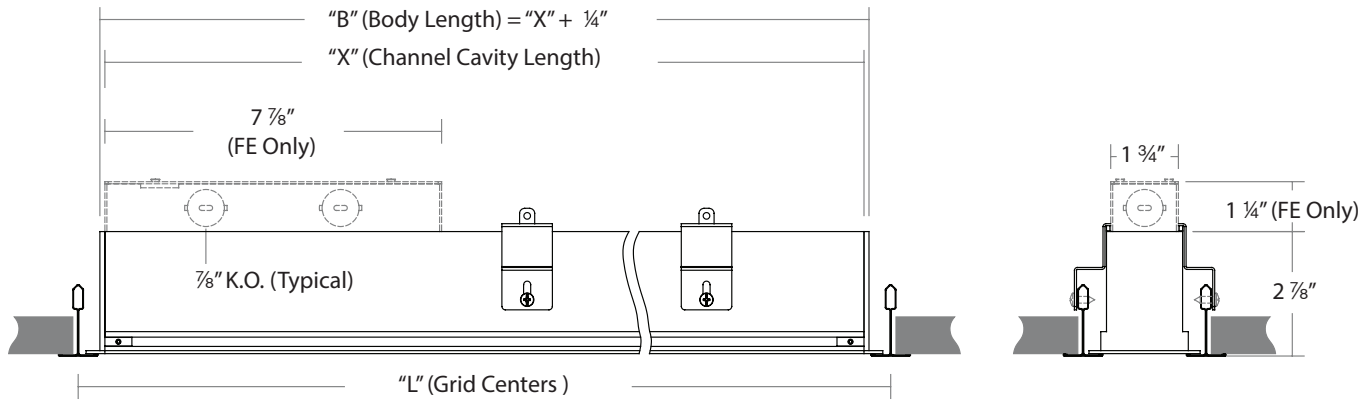

Individual Fixture Dimensions

Model	Channel Type	"X" Channel Cavity Length	"B" Body Length	"L" Grid Centers
S2CG*02-FE	Feed End	22 3/4"	23"	24"
S2CG*04-FE	Feed End	46 3/4"	47"	48"
S2CG*05	Extension	60"	N/A	N/A
S2CG*06-FE	Feed End	70 3/4"	71"	72"
S2CG*06	Extension	72"	N/A	N/A
S2CG*08-FE	Feed End	94 3/4"	95"	96"
S2CG*08	Extension	96"	N/A	N/A

VENTRIX Feed End (FE) recessed grid channels are supplied with two end caps. They may be used in individual channel instances, or with at the beginning of continuous channel runs by removing an end cap.

VENTRIX Extension (EXT) recessed grid channels are used in continuous channel runs and are NOT supplied with end caps.

FIG. 2 Recessed Mounting Options Overview

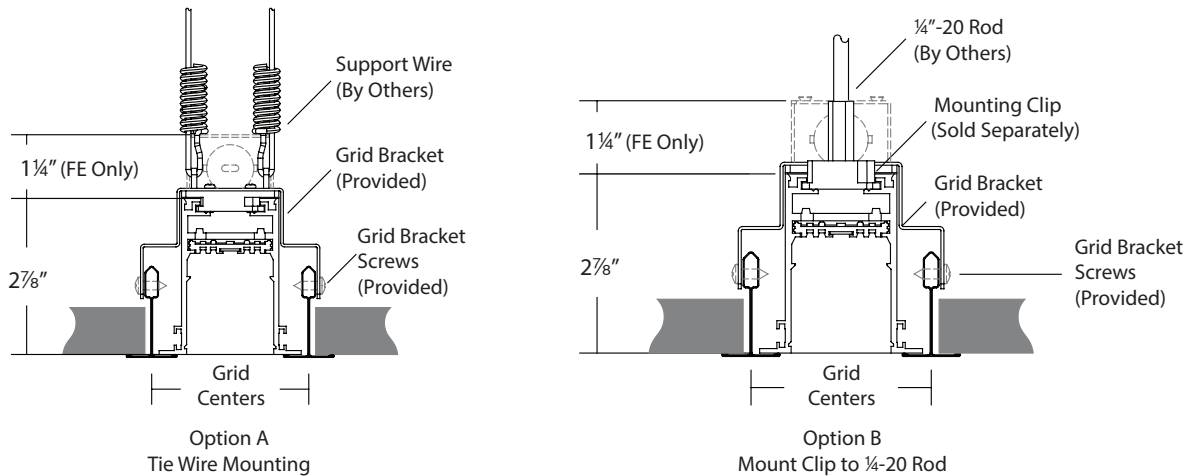

Minimum recommended number of support points per channel

S2CG*02	S2CG*04	S2CG*05	S2CG*06	S2CG*08
2	2	2	2	2

1. VENTRIX Recessed Grid Channel is possible to install in various methods. (See FIG. 2). Installer to select appropriate hardware and confirm appropriate installation means to meet project requirements.

wacighting.com

Phone (800) 526.2588

Fax (800) 526.2585

Headquarters, East Manufacturing Facility

44 Harbor Park Drive

Port Washington, NY 11050

South East Manufacturing Facility

1600 Distribution Ct

Lithia Springs, GA 30122

Central Manufacturing Facility

1700 South J Elmer Freeway, Ste 100

Cedar Hill, TX 75104

West Manufacturing Facility

1750 S Archibald Ave

Ontario, CA 91761

INSTALLATION INSTRUCTIONS

Recessed Grid Channel

S2CG*02-FE, S2CG*04-FE, S2CG*05, S2CG*06, S2CG*06-FE, S2CG*08, S2CG*08-FE

VENTRIX
BY WAC

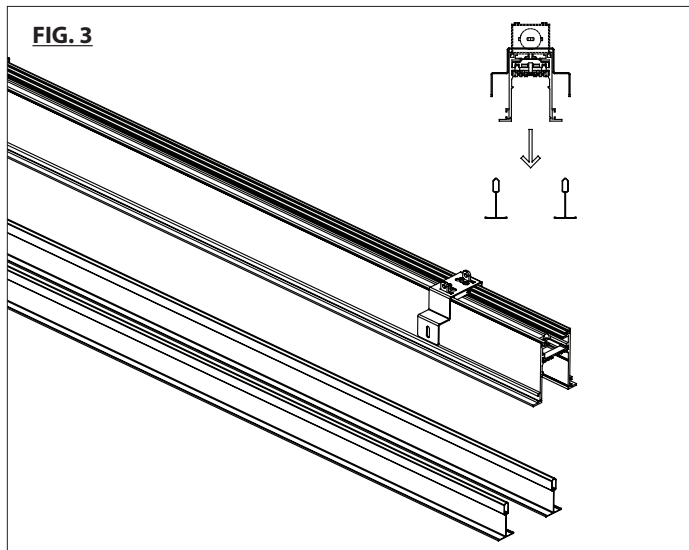

Option A: Tie Wire Mounting

A1. Prepare the suspended grid ceiling systems in accordance with channel dimensions requirements. Lay the channel inside the grid based on the grid and channel dimensions previously noted. (See **FIG. 3**).

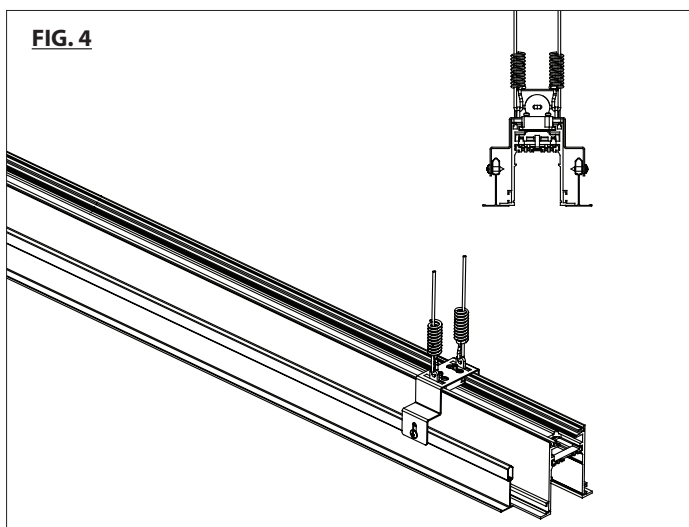

A2. For continuous runs, refer to I-connector join instruction. (See **FIG. 9** - Page 6). Support the channel via grid bracket using support (tie) wires (by others). (See **FIG. 4**).

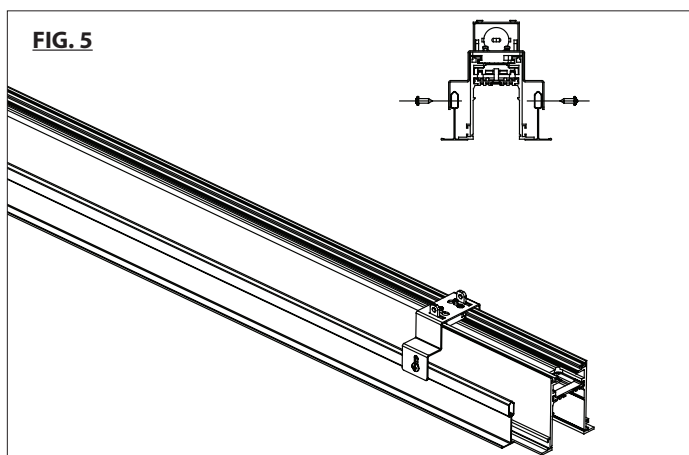

A3. To prevent movement of the channel during fixture installation and positioning, use the self-drilling grid bracket screws to secure the grid bracket to the grid tee. (See **FIG. 5**).

wacighting.com

Phone (800) 526.2588

Fax (800) 526.2585

Headquarters, East Manufacturing Facility

44 Harbor Park Drive

Port Washington, NY 11050

South East Manufacturing Facility

1600 Distribution Ct

Lithia Springs, GA 30122

Central Manufacturing Facility

1700 South J Elmer Freeway, Ste 100

Cedar Hill, TX 75104

West Manufacturing Facility

1750 S Archibald Ave

Ontario, CA 91761

INSTALLATION INSTRUCTIONS

Recessed Grid Channel

S2CG*02-FE, S2CG*04-FE, S2CG*05, S2CG*06, S2CG*06-FE, S2CG*08, S2CG*08-FE

VENTRIX
BY WAC

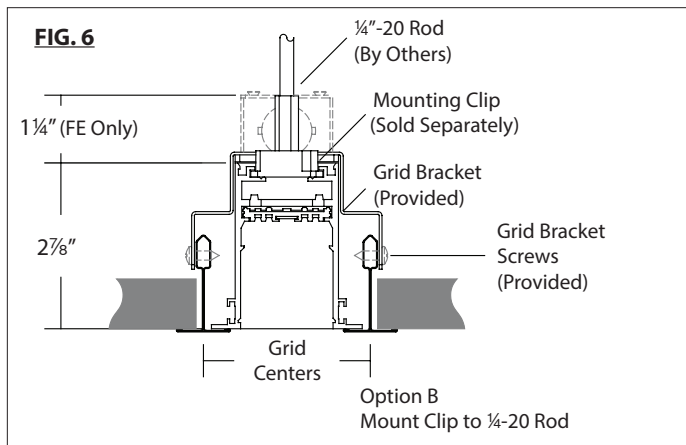

Option B: Mount Clip to 1/4-20 Rod Installation

B1. Install 1/4-20 threaded rod in appropriate locations. Prepare the suspended grid ceiling systems in accordance with channel dimensions requirements. Lay the channel inside the grid based on the grid and channel dimensions previously noted. (See **FIG. 6**).

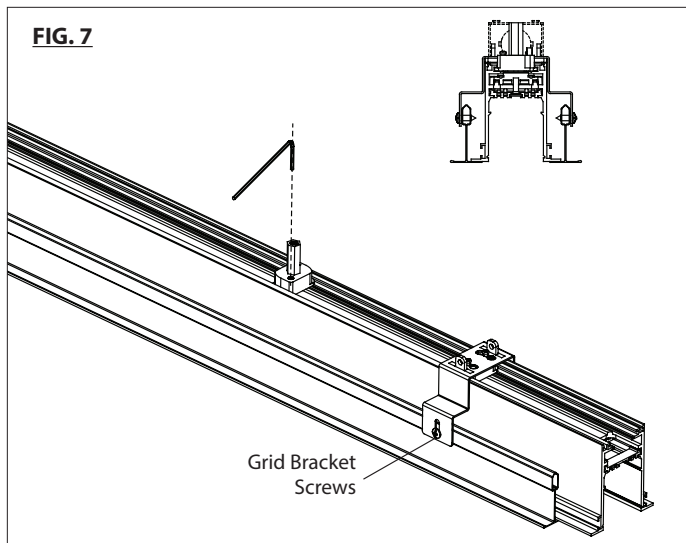

B2. For continuous runs, refer to I-connector join instruction. (See **FIG. 9** - Page 6). Install the mounting clip on the channel then lock it with allen key (See **FIG. 7**). Hang the channel, rotate the hexagonal stud on the mount clip to install and secure the 1/4-20 rod. (See **FIG. 7 & 8**).

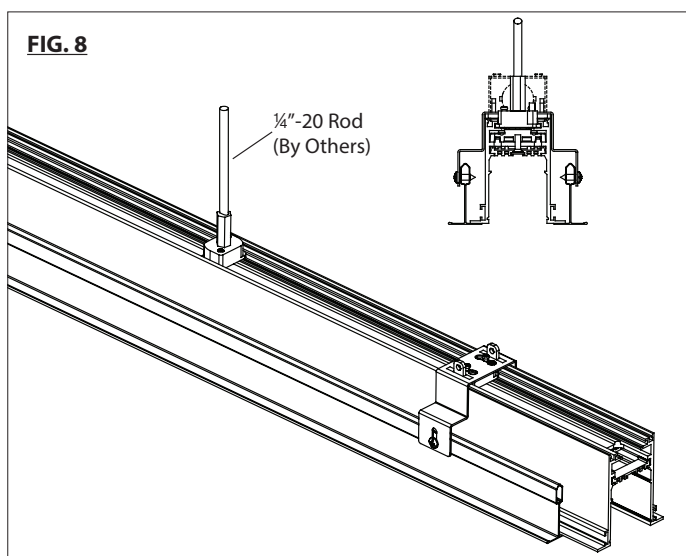

B3. To prevent movement of the channel during fixture installation and positioning, use the self-drilling grid bracket screws to secure the grid bracket to the grid tee. (See **FIG. 8**)

wacighting.com

Phone (800) 526.2588

Fax (800) 526.2585

Headquarters, East Manufacturing Facility

44 Harbor Park Drive

Port Washington, NY 11050

South East Manufacturing Facility

1600 Distribution Ct

Lithia Springs, GA 30122

Central Manufacturing Facility

1700 South J Elmer Freeway, Ste 100

Cedar Hill, TX 75104

West Manufacturing Facility

1750 S Archibald Ave

Ontario, CA 91761

INSTALLATION INSTRUCTIONS

Recessed Grid Channel

S2CG*02-FE, S2CG*04-FE, S2CG*05, S2CG*06, S2CG*06-FE, S2CG*08, S2CG*08-FE

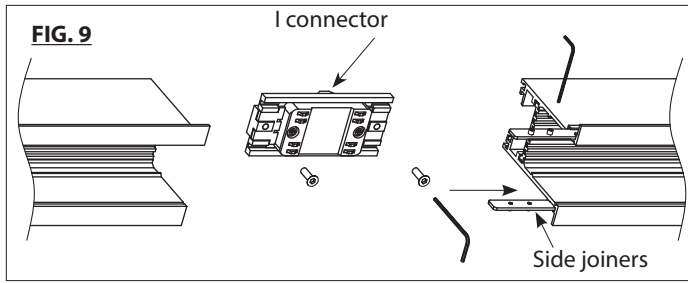

Channel to channel connection (Factory channel ends for uninterrupted bus bar)

1. Join channel sections mechanically and electrically with I connector and channel side joiners (See FIG. 9).

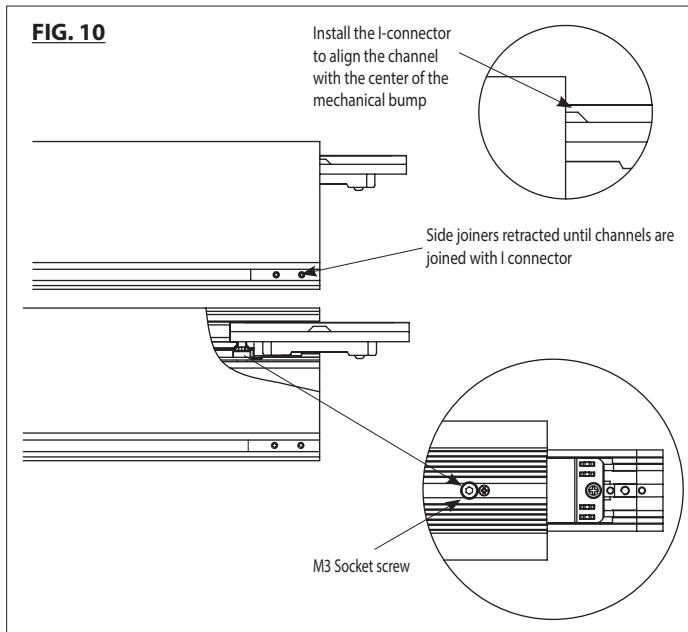

2. Insert I connector into one channel. Be sure I connector is fully inserted with mechanical bump aligned. A gentle tap with a rubber mallet may be necessary. Insert socket screw straight and gently tighten. Take caution not to strip threads. Note: Use of power tools not recommended (See FIG. 10).

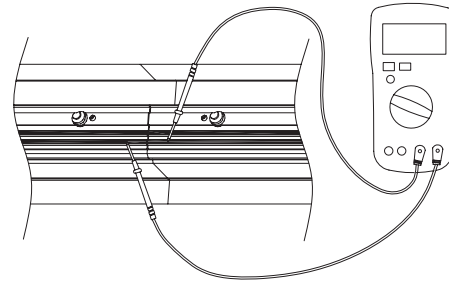

Note: Confirm continuity across each of the 4 bus bars after I connector is secured and prior to completing installation.

3. Repeat for other side. Lock I connector with screws from bottom of channel. After I connector is installed on both ends, slide side joiners to span both sides of channels and secure by tightening set screws. **Note:** Use of power tools not recommended (See FIG. 11).

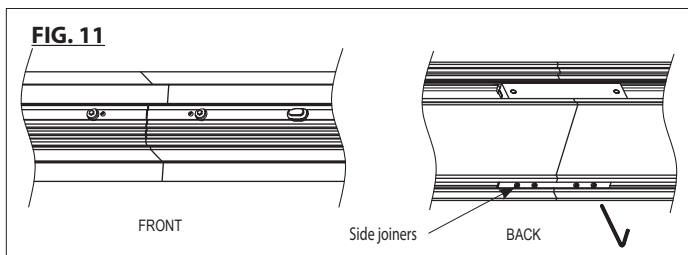

Channel Cutting

1. Last channel in a run can be field cut to terminate the run. Use a chop saw with good condition blade rated for metal cutting. Confirm cut is perpendicular and remove any burrs or filings. Reattach end cap (See FIG. 12).

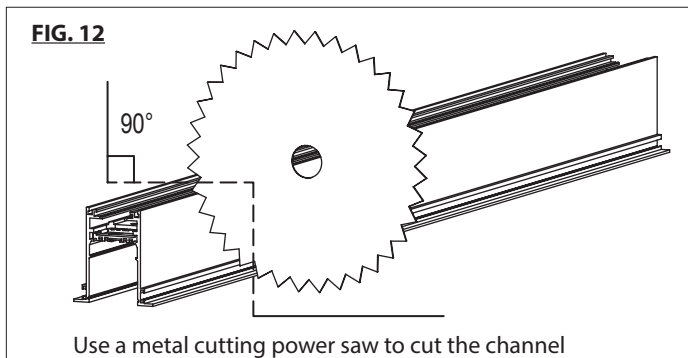

Note: Field cuts result in end of run condition and accepts end caps. Cut ends are not compatible with general channel connectors.

INSTALLATION INSTRUCTIONS

Recessed Grid Channel

S2CG*02-FE, S2CG*04-FE, S2CG*05, S2CG*06, S2CG*06-FE, S2CG*08, S2CG*08-FE

VENTRIX
BY WAC

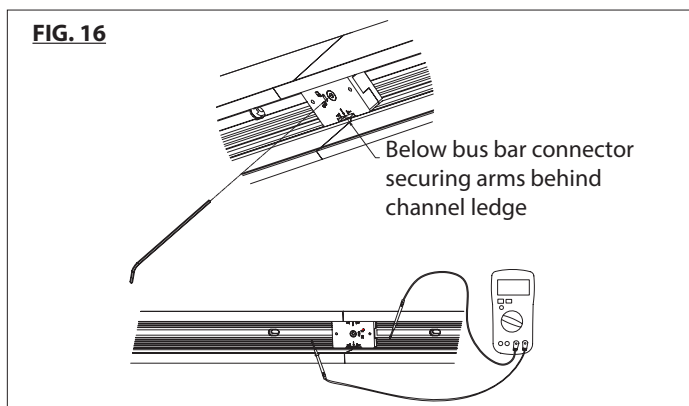
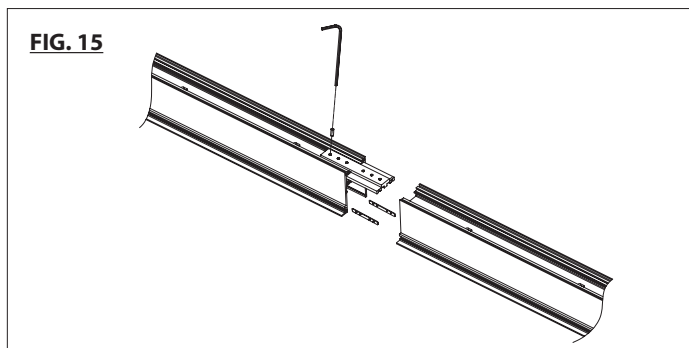
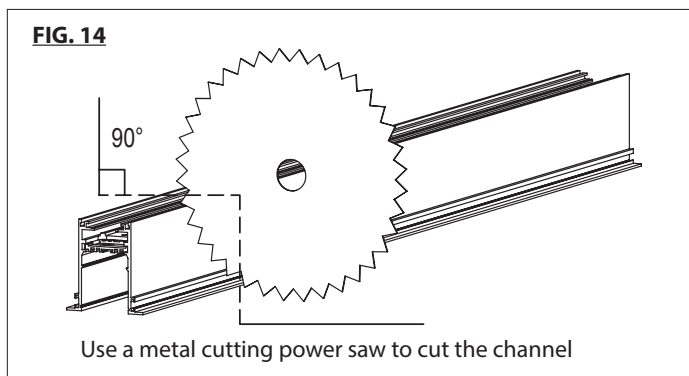
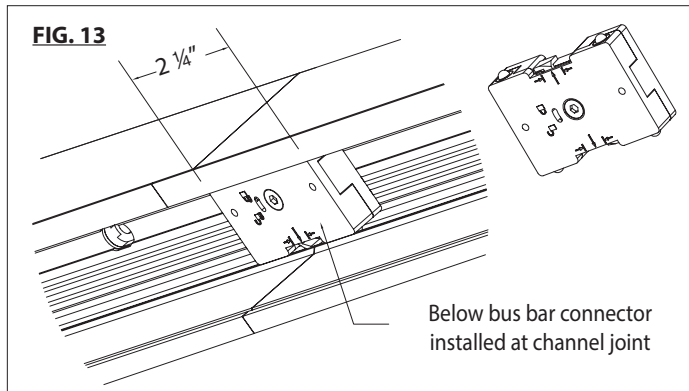

Channel to channel connection (Field cut channel end(s) for interrupted bus bar)

1. If necessary to field cut channel at channel to channel connection, it is possible to create joint mechanically and electrically using below bus bar I connector kit S2C-IB-BK. Note: with this setup, a connector will be installed below bus bar plane which may interfere with installation of fixture elements. Confirm this will be acceptable in project prior to proceeding (See **FIG. 13**).

Note: Some 2' and 4' VENTRIX fixture elements can span below bus bar connector. Reference line drawings on spec sheets.

2. Field cut appropriate channel. Use a chop saw with good condition blade rated for metal cutting. Confirm cut is perpendicular and remove any burrs or filings. (See **FIG. 14**).

3. Insert top connector (S2C-ID) into top side of channel and channel side joiners into side profile. Position connector and joiners centered between channels and tighten all set screws. (See **FIG. 15**).

4. To make electrical connection, insert below bus bar connector into bus bar at channel joint. Center the connector in the appropriate position (channel joint is between connector arrows) and push in firmly. Securing arms should be behind channel ledge. Then, tighten central screw to lock the connector in position. Confirm connector is mechanically secure and has electrical continuity across. (See **FIG. 16**)

wacighting.com

Phone (800) 526.2588

Fax (800) 526.2585

Headquarters, East Manufacturing Facility

44 Harbor Park Drive

Port Washington, NY 11050

South East Manufacturing Facility

1600 Distribution Ct

Lithia Springs, GA 30122

Central Manufacturing Facility

1700 South J Elmer Freeway, Ste 100

Cedar Hill, TX 75104

West Manufacturing Facility

1750 S Archibald Ave

Ontario, CA 91761

INSTALLATION INSTRUCTIONS

Recessed Grid Channel

S2CG*02-FE, S2CG*04-FE, S2CG*05, S2CG*06, S2CG*06-FE, S2CG*08, S2CG*08-FE

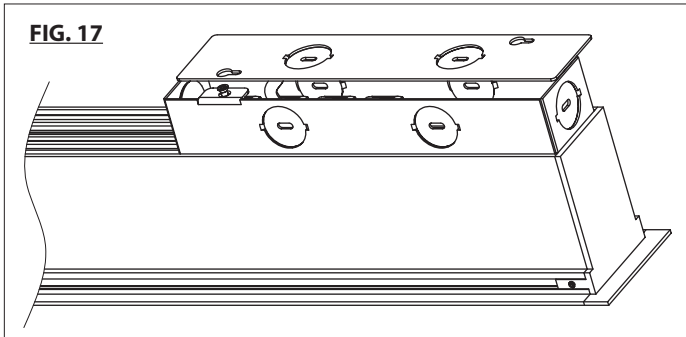

Channel Wiring (S2CG*-FE)

1. Loosen the screws on the junction box and remove the cover (See FIG. 17).

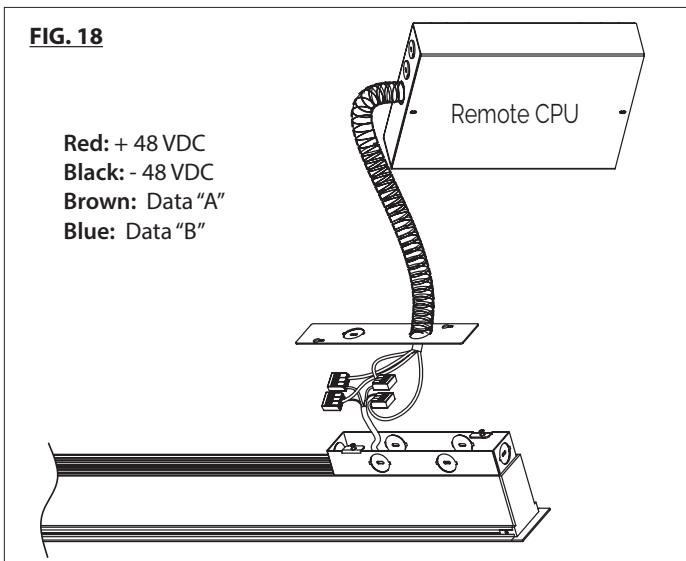

2. Remove desired knockout for wiring. Make wire connection between CPU and Channel with appropriate conductors and conduit (by others) (See FIG. 18).

Reference VENTRIX CPU instructions for CPU specific instructions.

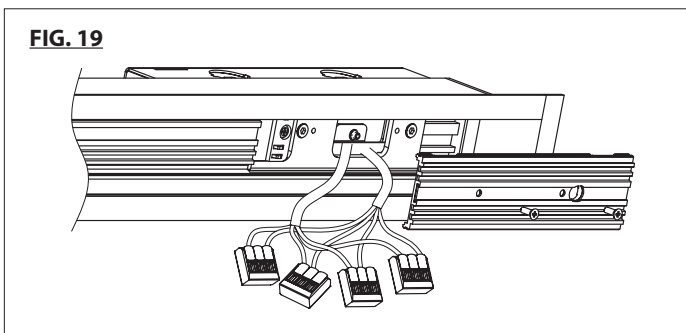

Wiring inspection

1. It is possible to inspect wiring from inside of channel. Loosen two small screws located at the feed end of the channel to remove small section of channel bus bar and gain access to wiring (See FIG. 19).