

SAFETY INFORMATION

Please read and understand this entire manual before attempting to assemble, install or operate the product.

WARNING

- RISK OF ELECTRIC SHOCK - Before beginning installation, turn off electricity at the circuit breaker box or the main fuse box.
- RISK OF FIRE - Use bulbs specified by the markings and/or labels on the fixture.

CAUTION

- For your safety, read instructions completely before beginning installation.
- If in doubt about electrical installation, consult a licensed electrician.
- Turn off electricity to fixture before replacing the bulb(s).
- Do not touch the bulb with bare hands, use a cloth or glove.

TOOLS REQUIRED

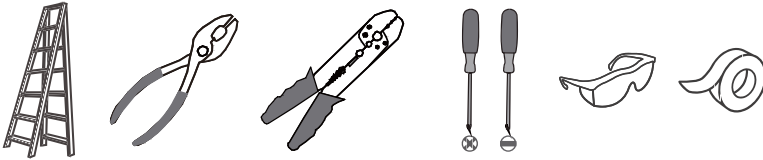

CARE AND MAINTENANCE

- Wipe clean using soft, dry cloth or static duster. Always avoid using harsh chemicals and abrasives to clean fixture as they may damage the finish.

If you need further assistance call Quozel Customer Care at 1-800-645-3184 (9:00am – 5:00pm EST), or visit us on-line at www.quozel.com.

PACKAGE CONTENTS

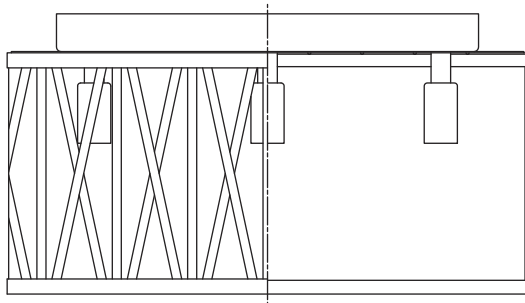

A Fixture Body
x 1



B Beads String
x 49
(1pc Replacement
String Included)

MOUNTING HARDWARE



AA Crossbar Assembly
x 1

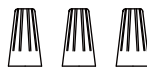

BB Wire Connector
x 3



CC Outlet Box Screw
x 2

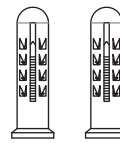

DD Wall Anchor
x 2

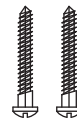

EE Screw
x 2



FF Flat Washer
x 2

INSTALLATION

1 Install Crossbar Assembly

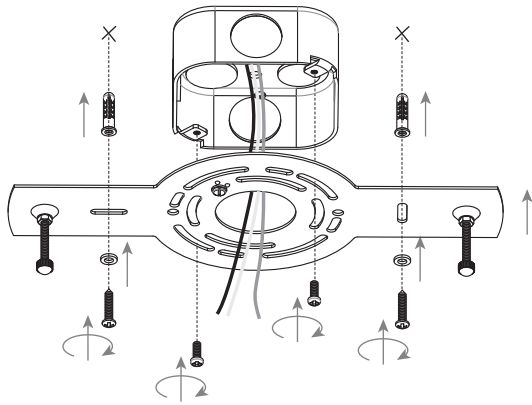

2 Wiring

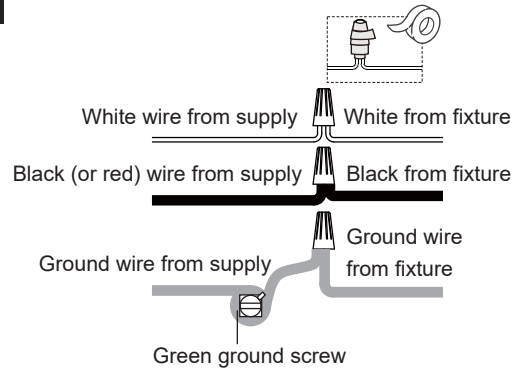

3 Install Fixture Body

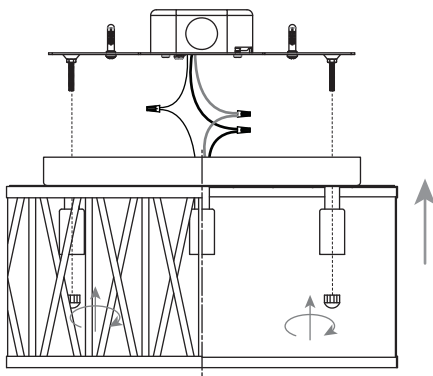

4 Install Bead Strings

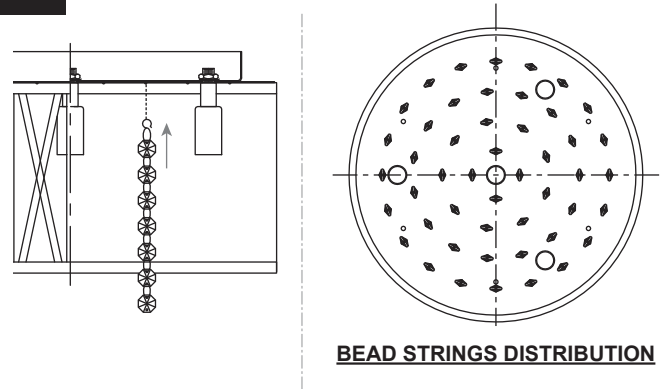

5 Install Bulbs

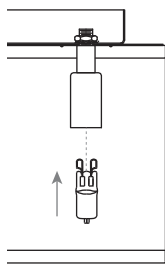

Install four correct bulbs referring to fixture markings and/or labels for maximum wattage.

Recommended Bulb type (not included):

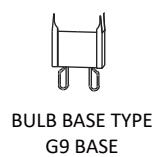

BULB BASE TYPE
G9 BASE

40W MAX



BULB SHAPE
TYPE G9 T4
XENON CLEAR

* Do not touch the bulb with bare hands, use a cloth or glove.

Your installation is now complete! Restore electricity and save this sheet for future reference.