

ARTERIOS

PALMA PENDANT

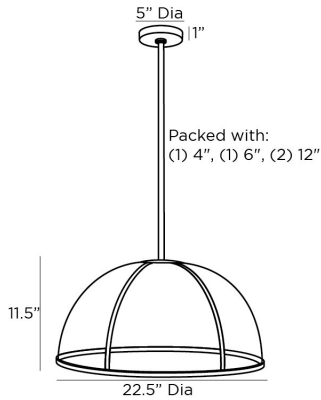

49519
 H: 16.5 IN, Dia: 22.50 IN
 Natural Rattan
 Contract Suitable As Is

Drawing from interior design of the 1970s, the Palma pendent is constructed in a classic domed pendant shape of natural woven natural rattan. The piece is made modern with an antique brass iron frame, pipe and canopy. Finish will vary. Damp-rated, although limited covered outdoor areas may affect finish.

APPEARANCE

Material	Iron, Rattan
Finish	Antique Brass, Natural
Finish Will Vary	true
Top Coat/Sealant	false

DIMENSIONS

Pendant	46.5
Minimum Hanging Height	H: 11.5 IN, Dia: 22.50 IN
Canopy	16.5 IN
	H: 1 IN, Dia: 5.00 IN

WIRING

Rating	Damp
Cord	7 FT, Clear/Silver, SVT
Socket	1, Type A - E26
Photographed Bulb	5" Frosted Globe Bulb
Maximum Watt	100
Voltage	110-120 V

CERTIFICATIONS

Certifications	Mexico Australia, European Union, United Arab Emirates, United States, Canada
----------------	--

COMPLIANCY

UL/ETL	Yes
CB	Yes
RoHS	true

SHIPPING

Product Weight	8.2 LBS
Gross Weight 1	13.2 LBS
Gross Weight 2	0 LBS
Shipping Box 1	H: 26 IN, L: 26 IN, W: 16 IN
Shipping Box 2	H: 0 IN, L: 0 IN, W: 0 IN

REPLACEMENT PARTS

Replacement Part 1	PIPE-180
Replacement Part 1 Dim	(1) 4", (1) 6", and (1) 12"
Replacement Part 2	CANOPY-248
Replacement Part 2 Dim	1" x 6"

CONTRACT

Contract Suitable	true
-------------------	------