

Collection: Stella

Product #: CHB0070-03

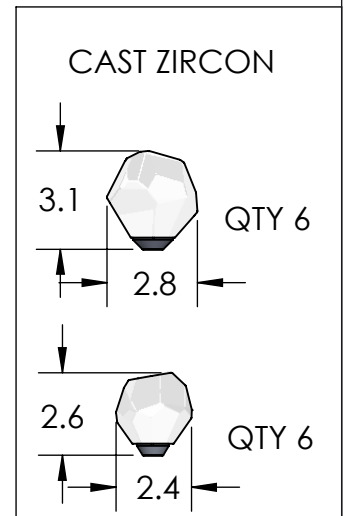
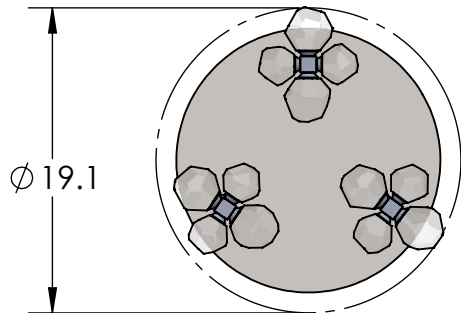
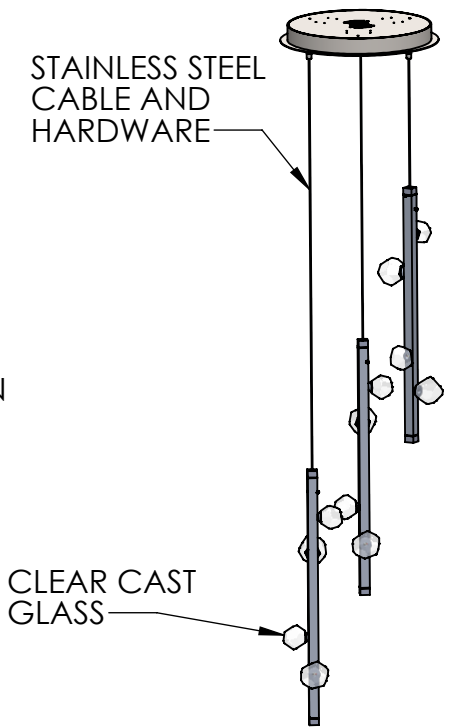
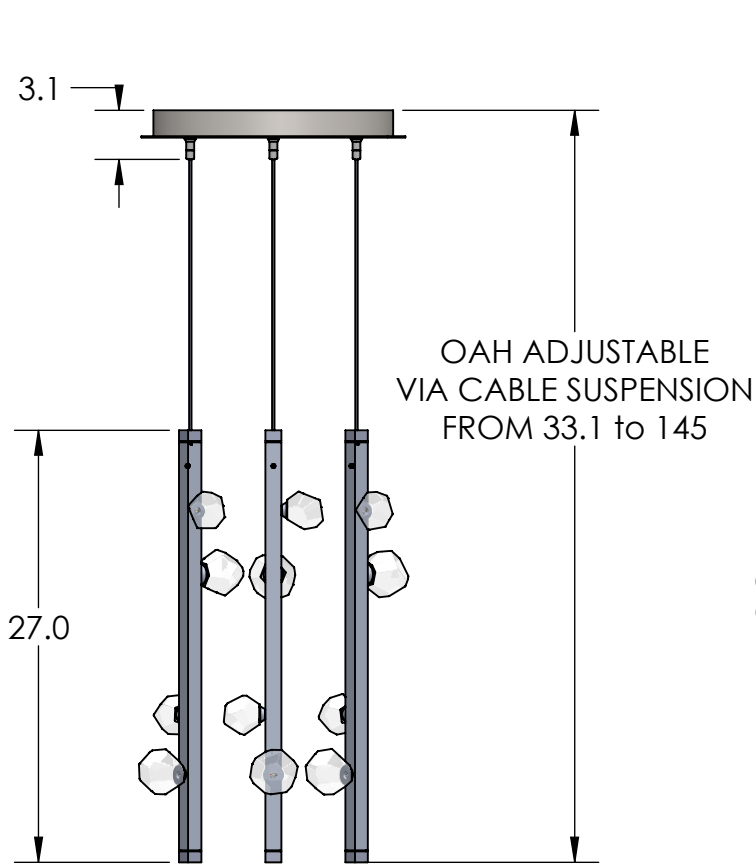

All dimensions are shown in inches unless otherwise stated. Visit [hammeronstudio.com](http://hammeronstudio.com) for product options.

12/8/2020 (A)

Mounting Packet: X	Weight(lbs.): 30	Electrical Type: LED	CCT: 3000K
UL Location: DRY		Elec. Qty: 12	Wattage: 15 Voltage: 120
Finish: SEE WEBSITE FOR OPTIONS		Source Lumens: Ambient: 1860	
Top Diffuser: N/A		Dimmable: Forward/Reverse Phase To 1%	
Bottom Diffuser: N/A		CRI: 93+	Power Factor: >0.9

### Canopy Mounting Detail

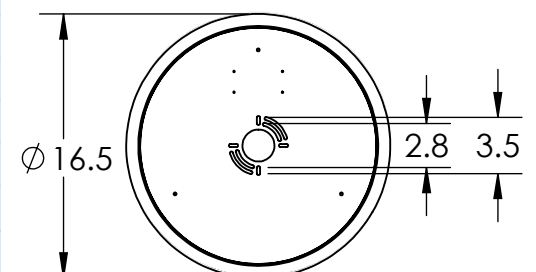

MOUNTS DIRECTLY TO J-BOX

All Hammerton fixtures are handcrafted by artisans. Subtle imperfections reflect the mark of the artisan and should be expected in any handcrafted product. Dimensions may vary up to 7/8".  
 © Copyright 2020. All rights in design, detail or invention of this drawing are reserved as the property of Hammerton. Any imitation or adaptation without written consent is strictly prohibited.