

ARTERIOS

TALLOW CHANDELIER

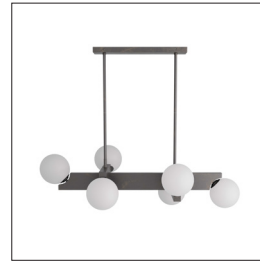
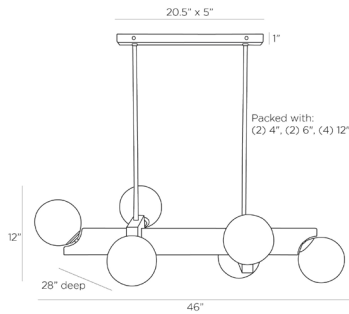

DRC02
H: 17 IN, W: 46 IN, D: 28 IN
English Bronze
Contract Suitable As Is

The graphic Tallow chandelier is an attention-getter, forged in an English bronze industrial-style steel beam, with offset frosted glass globes that float around the linear center. The bold chandelier, in English bronze finished steel, features a dual pipe suspension and a linear canopy. Damp-rated, although limited covered outdoor conditions may affect finish.

APPEARANCE

Material	Glass, Steel
Finish	Frosted
Top Coat/Sealant	true

DIMENSIONS

Chandelier	H: 12 IN, W: 46 IN, D: 28 IN
Minimum Hanging Height	17 IN
Maximum Hanging Height	47 IN
Canopy	H: 1 IN, W: 20.5 IN, D: 5 IN

WIRING

Rating	Damp
Cord	10 FT, Black/White, SVT
Socket	6, Type A - E26
Photographed Bulb	Medium Clear Tubular Bulb
Maximum Watt	60
Voltage	110-120 V

CERTIFICATIONS

Certifications	Mexico Australia, European Union, United Arab Emirates, United States, Canada
----------------	--

COMPLIANCY

UL/ETL	Yes
CB	Yes
RoHS	true

SHIPPING

Product Weight	30 LBS
Gross Weight 1	40.9 LBS
Gross Weight 2	0 LBS
Shipping Box 1	H: 41.75 IN, L: 28 IN, W: 12.6 IN
Shipping Box 2	H: 0 IN, L: 0 IN, W: 0 IN

REPLACEMENT PARTS

Replacement Part 1	PIPE-487
Replacement Part 1 Dim	(1) 4", (1) 6", (1) 12"
Replacement Part 2	CANOPY-633
Replacement Part 2 Dim	1" x 20" x 4"

CONTRACT

Contract Suitable	true
-------------------	------