

ARTERIOS

CELESTIAL PENDANT

WINDSOR SMITH

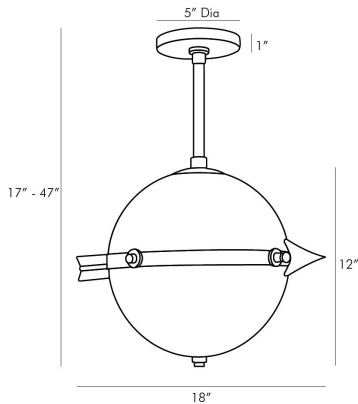

DS49036

H: 17 IN, W: 18 IN, D: 12 IN

Vintage Silver, Antique Brass, Opal Glass
Contract Suitable As Is

We bow down to this beautifully romantic pendant. Features a simple, opal glass orb wrapped with a dark bronze steel band, embellished with decorative vintage silver elements. See where the arrow of the Celeste Pendant will take you! Additional pipe available (PIPE-210). Damp-rated, although limited covered outdoor areas may affect finish.

APPEARANCE

Material	Glass, Steel
Finish	Bronze, Opal, Vintage Silver
Top Coat/Sealant	true
Link	Welded

DIMENSIONS

Minimum Hanging Height	17 IN
Maximum Hanging Height	47 IN
Canopy	H: 1 IN, Dia: 5.00 IN

WIRING

Rating	Damp
Cord	10 FT, Black, SVT
Socket	2, Type A- E26 Other
Maximum Watt	60
Voltage	110-120 V

CERTIFICATIONS

Certifications	Mexico United States, Canada
----------------	---------------------------------

COMPLIANCY

UL/ETL	Yes
RoHS	true

SHIPPING

Product Weight	8 LBS
Gross Weight 1	11 LBS
Shipping Box 1	H: 14 IN, L: 17 IN, W: 14 IN

ADDITIONAL INFO

Features	Assembly Required
----------	-------------------

REPLACEMENT PARTS

Replacement Part 1	PIPE-210
Replacement Part 1 Dim	(1) 4", (1) 6", (1) 12"
Replacement Part 2	CANOPY-289
Replacement Part 2 Dim	1" x 5" Dia

CONTRACT

Contract Suitable	true
-------------------	------