

ASSEMBLY AND INSTALLATION INSTRUCTIONS

P0153 / P0154 / P0241 / P0267 / P0402

WARNING: TO AVOID RISK OF ELECTRICAL SHOCK, BE SURE TO SHUT OFF POWER WHILE INSTALLING OR SERVICING THIS FIXTURE.

NOTES: 1. Before installing, consult local electrical codes for wiring and grounding requirements.
2. Read and save this instruction.

Hardware Package (included):

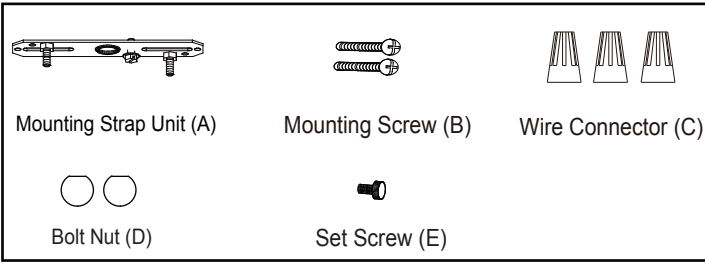

Installation Steps

Turn off the power at fuse or circuit box.

1. Rod Connections:

- Thread the fixture wire from the fixture through the lower rod, then secure the lower rod onto fixture using the threaded pipe.
- Thread the fixture wire through the middle rod, and then secure the middle rod onto the lower rod using the threaded pipe.
- Thread the fixture wire through the upper rod and the hook, then secure the upper rod onto the middle rod using the threaded pipe, attach the hook onto the upper rod using the threaded pipe.

The height can be adjustable to 15"~57", by using the rods.

- Thread the fixture wire through canopy, then hook the rod assembly to the loop.
- Unscrew two bolt nuts (D), remove mounting strap unit (A) from canopy.
- Attach the mounting strap unit (A) to outlet box by using two mounting screws (B).
- Pull out the source wires from the outlet box. Make wire connections using wire connectors (C) as follows:
 - Connect the smooth-coated wire (marked) from the fixture to the black wire from the power source.
 - Connect the ribbed-coated wire (unmarked) from the fixture to the white wire from the power source.
 - Attach the fixture ground wire to the mounting strap unit (A) with the green ground screw, then connect it to the house ground wire with a wire connector (C).Carefully put the wires back into the outlet box.

- Attach the canopy to the mounting strap unit (A) by inserting the fixture mounting screws, and secure it with two bolt nuts (D).

- Install 1 x 60W Max. medium base bulb (not included). See relamping label at socket area or packaging for maximum wattage allowed.



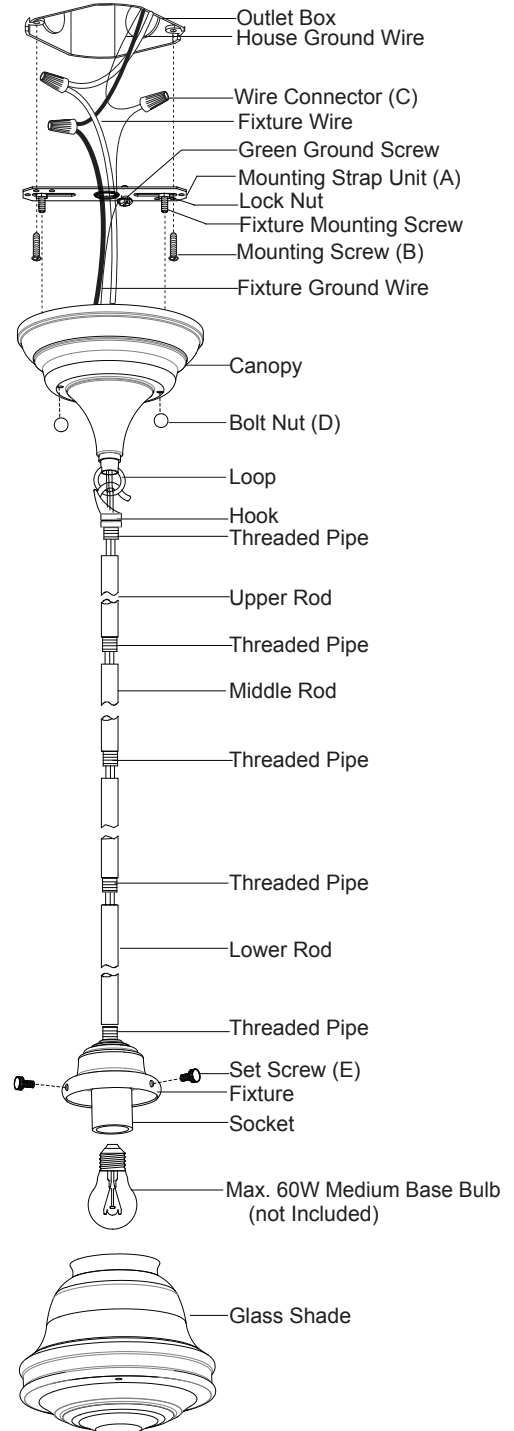

- Attach the glass shade to the fixture, secure it with three set screws (E). (Don't over tighten.)



Turn on the power at fuse or circuit box.

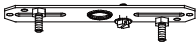

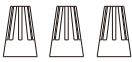
The following parts are available for reorder if damaged or missing.

Spare Parts List:

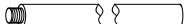
 Mounting Strap Unit (A)	 Mounting Screw (B)	 Wire Connector (C)	Assembly Kit 6008MM (1 SET) for P0154 / P0267 5773MM (1 SET) for P0153 / P0241 6774MM (1 SET) for P0402
 Bolt Nut (D)	 Set Screw (E)		

 12" Rod 4644RR for P0154 / P0267 3052RD for P0153 / P0241 3330RD for P0402	 6" Rod 4645RR for P0154 / P0267 3051RD for P0153 / P0241 3331RD for P0402	 3" Rod 4646RR for P0154 / P0267 3050RD for P0153 / P0241 3376RD for P0402	 Glass Shade 9681CS for P0153 / P0267 9680MI for P0154 / P0241 / P0402
--	---	---	--

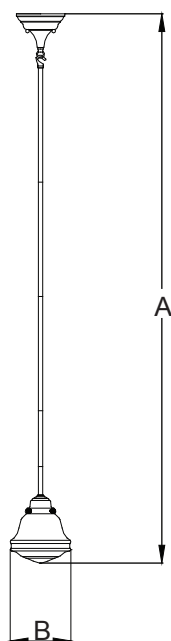

A: 15"~57"

B: 6-1/4"

1 Year Warranty

Vaxcel warrants all of our products against defects in workmanship and finishes for one year following the date of shipment.

Exclusions: This warranty does not include the failure of products from extreme acts of nature; environmental conditions not suited for the products intended use; operation in temperatures outside of the range specified in the instruction manual; usage with improper power supply, power surges or dips. For coastal locations, some corrosion is considered normal for the environment.

Vaxcel reserves the right to repair, replace or issue a credit for any properly installed product, provided it is returned per RMA instruction. This warranty is limited to the cost of the product only and does not extend to transportation, installation or replacement costs.

How can warranty service be obtained?

info@vaxcel.com

1-800-482-9235