

MONDO

FR49296PCM



Bulbs: 60W G9

Replacement Parts: GLASS: R49292GL BULB SHIELD: R4750BLSH

ASSEMBLY INSTRUCTIONS

Assembly of this fixture will be accomplished by first assembling the fixture, making all necessary electrical connections and then hanging the fixture.

SAFETY WARNING: Read wiring and grounding instructions [FRIS 18] and any additional directions. Turn power supply off during installation. If new wiring is required, consult a qualified electrician or local authorities for code requirements.

STEP 1

- 1 Rotate arms (a) and (a1) until they are equally spaced 30 degrees apart - See Drawing 1.
- 2 To install glass, remove socket ring (b) from socket (d) - See Drawing 2.
- 3 Slip glass (c) over socket (d).
- 4 Thread socket ring (b) onto socket (d) and tighten using socket ring tool provided.
- 5 Fixture can now be lamped accordingly.
- 6 Thread bulb shield (e) onto socket (d).

STEP 2 Refer to Hanging Instruction Sheet [FRIS19-20] to hang fixture and complete installation.

[DRAWING 1]

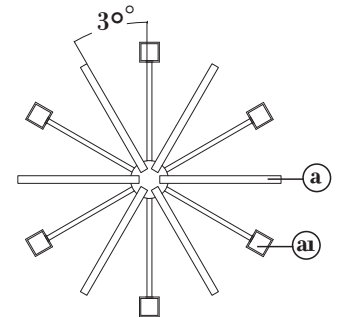

[DRAWING 2]

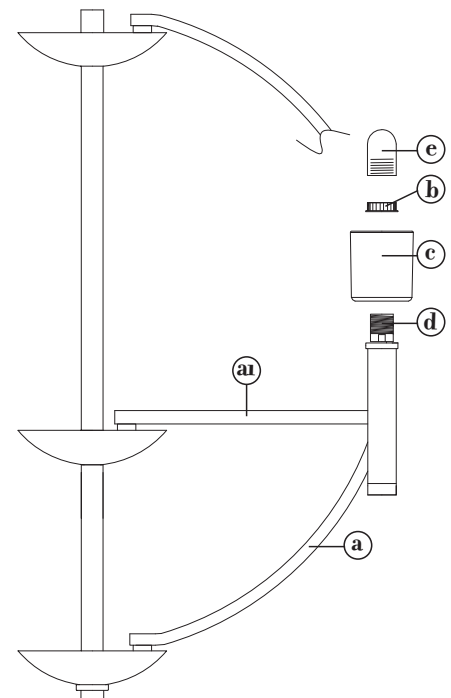

FREDRICK RAMOND

ESTABLISHED 1965

800.421.3517 WWW.FREDRICKRAMOND.COM

2.17.09

FRIS19-20

CABLE HANGING INSTRUCTIONS

SAFETY WARNING: Read wiring and grounding instructions [FRIS 18] and any additional directions. Turn power supply off during installation. If new wiring is required, consult a qualified electrician or local authorities for code requirements.

STEP 1

- 1 Shut off electrical current before starting. If the fixture you are replacing is turned on and off by a wall switch, simply turn the switch off. If not, remove the appropriate fuse (or open the circuit breakers) until the fixture is dead.
 - DO NOT restore current - either by fuse, breaker or switch - until the new fixture is completely wired and in place.

STEP 2

- 1 Prepare mounting strap (a) by threading the two long screws (b) through the appropriate mounting holes that will line up with the mounting holes in the canopy (c) - See Drawing 1.
- 2 Install mounting strap (a) to junction box (d) with the two short screws (e) (Not Provided), making sure the installed screw (b) are facing down.

STEP 3

- 1 Taking the cable (f), determine the length you require to hang the fixture and mark this length with a marking pen. Note: To do this, measure the distance between the floor and the ceiling. From that distance, subtract the distance that the bottom of the fixture will be above the floor and the height of the fixture.
- 2 To adjust cable, pull cable (f) through spring loaded locking mechanism (g) up to the mark previously made. Note: the cable (f) can be pulled through but can not be pulled back out - See Drawing 2.
- 3 Hook the hook (h), attached to canopy (c) to mounting strap (a). This will allow the fixture to hang while adjustments are made.
- 4 Before wiring, hold the canopy (c) up to the ceiling and make the final cable (f) length adjustments, doing this in small increments until the desired height is achieved.
- 5 Make electrical connections from supply wire to fixture lead wires. Refer to instruction sheet [FRIS18] and follow all instructions to make all necessary wiring connections.
- 6 Feed cable (f) through one hole of the retainer bracket (i), slide retainer bracket (i) along cable until it is approximately 6" from the canopy and then tighten the screw (j) to lock retainer bracket in place.
- 7 Loop cable (f) around and feed end through remaining hole in the retainer bracket (i). When there is about a 1" loop formed, tighten screw (k) to lock cable in place.
- 8 Excess cable can be rolled up and placed in canopy.
- 9 Slip canopy (c) over mounting screws (b) and thread on decorative knobs (l).
- 10 Adjust wire keeper (m) on cable (f) to eliminate sagging.
- 11 To secure wire keeper (m) tighten set screw (n) with allen wrench.

Note: If during the adjustment process too much cable is pulled up, the spring loaded locking mechanism can be released by taking a screw driver and pushing up on the center cylinder of the locking mechanism. This will release the spring pressure and allow the cable to be pulled back out (use caution to prevent the cable from being damaged).

[DRAWING 1]

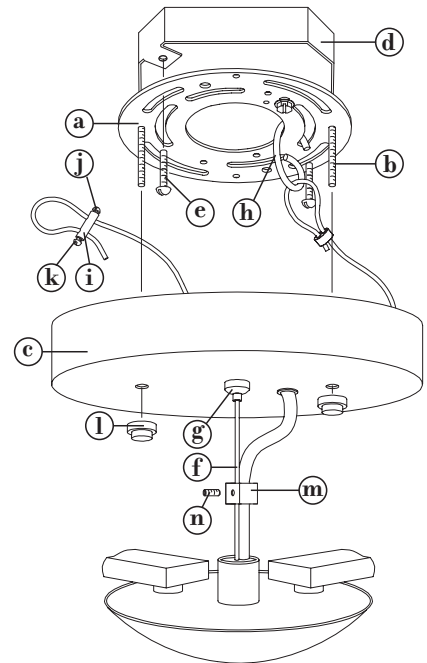

[DRAWING 2]

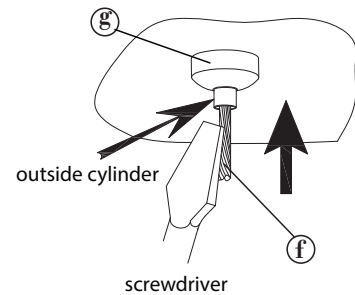

WIRING AND GROUNDING INSTRUCTIONS

SAFETY WARNING: Read wiring and grounding instructions [FRIS 18] and any additional directions. Turn power supply off during installation. If new wiring is required, consult a qualified electrician or local authorities for code requirements.

STEP 1 WIRING INSTRUCTIONS

Indoor Fixtures

- 1 Connect positive supply wire (a) (typically black or the smooth, unmarked side of the two-conductor cord) to positive fixture lead (b) with appropriately sized twist on connector - See Drawings 1 or 2.
- 2 Connect negative supply wire (c) (typically white or the ribbed, marked side of the two-conductor cord) to negative fixture lead (d).
- 3 Please refer to the grounding instructions below to complete all electrical connections.

Outdoor Fixtures

- 1 Connect positive supply wire (a) (typically black or the smooth unmarked side of the two-conductor cord) to positive fixture lead (b) with appropriately sized twist on connector - See Drawings 2 or 3.
- 2 Connect negative supply wire (c) (typically white or the ribbed, marked side of the two-conductor cord) to negative fixture lead (d).
- 3 Cover open end of connectors with silicone sealant to form a watertight seal.
 - If installing a wall mount fixture, use caulk to seal gaps between the fixture mounting plate (backplate) and the wall. This will help prevent water from entering the outlet box. If the wall surface is lap siding, use caulk and a fixture mounting platform specially.
- 4 Please refer to the grounding instructions below to complete all electrical connections.

STEP 2 GROUNDING INSTRUCTIONS

Flush Mount Fixtures

For positive grounding in a 3-wire electrical system, fasten the fixture ground wire (e) (typically copper or green plastic coated) to the fixture mounting strap (1) with the ground screw (2) - See Drawing 1.

Note: On straps for screw supported fixtures, first install the two mounting screws in strap.

Any remaining tapped hole may be used for the ground screw.

Chain Hung Fixtures

Loop fixture ground wire (e) (typically copper or green plastic coated) under the head of the ground screw (2) on fixture mounting strap (1) and connect to the loose end of the fixture ground wire directly to the ground wire of the building system with appropriately sized twist-on connectors - See Drawing 2.

Post-Mount Fixtures

Connect fixture ground wire (e) (typically copper or green plastic coated) to power supply ground with appropriately sized twist-on connector inside post. Cover open end of connector with silicone sealant to form a watertight seal - See Drawing 3.

[drawing 1]

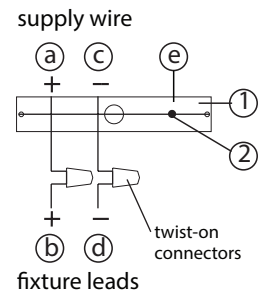

[drawing 2]

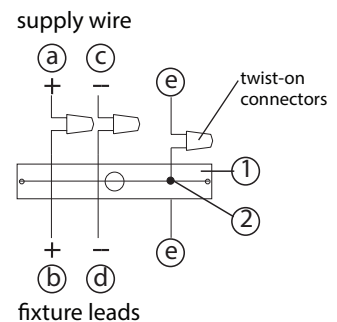

[drawing 3]

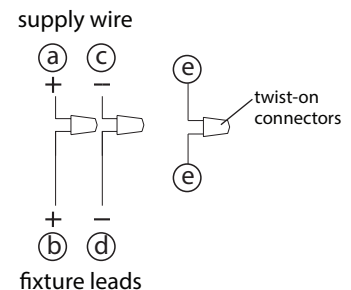

FREDRICK RAMOND
ESTABLISHED 1965

A Division of Hinkley Lighting, Inc.
33000 PIN OAK PARKWAY | AVON LAKE, OHIO 44012
toll free 800.446.5539 | phone 440.653.5500