

Tools Required

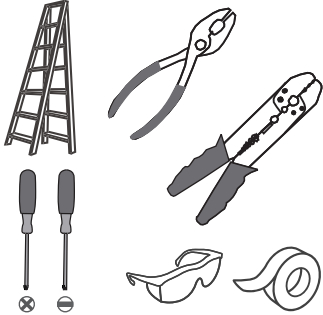

Light Source

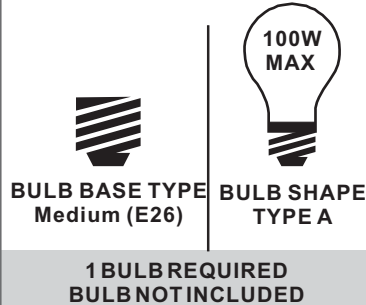

Warnings and Cautions

Turn off the electricity at the circuit breaker before installation. Consult a licensed electrician if in doubt about installation.

Turn off power to the fixture and allow the bulbs to cool before replacing.

Package Contents

Preparation: Identify and inspect all parts before beginning the installation.

Missing or damaged parts? Contact your original place of purchase.

PARTS BAG

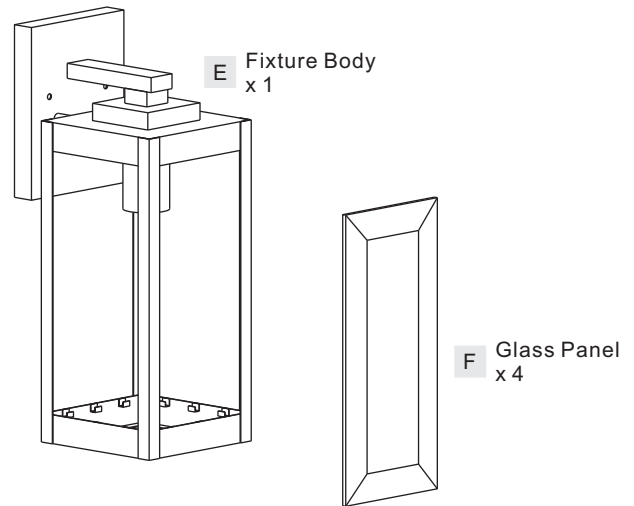
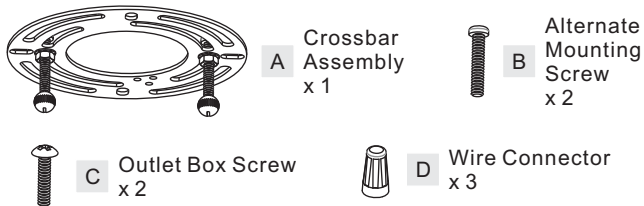
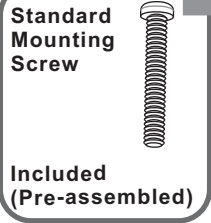

Table of Contents

Alternate Mounting Screw	Crossbar Assembly	Glass Panel	Wiring	Fixture Body	Bulb	Caulk
STEP 1	STEP 2	STEP 3	STEP 4	STEP 5	STEP 6	STEP 7

STEP 1

OPTION 1



OPTION 2

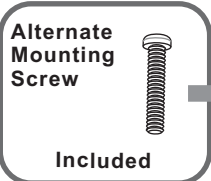

skip to next page

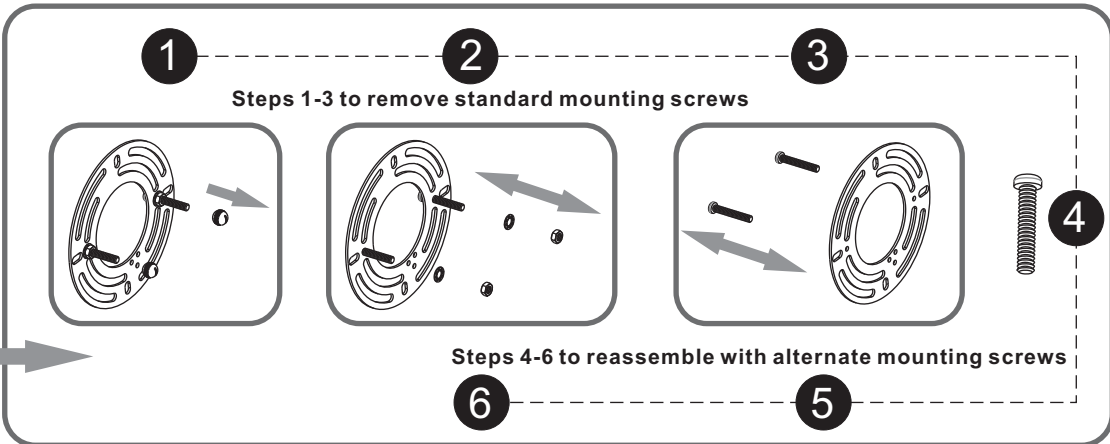

STEP 2

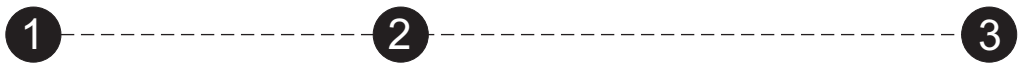

Step 1
Install crossbar assembly

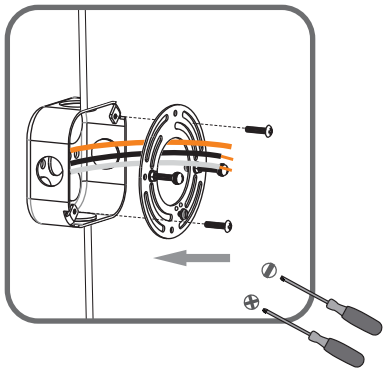

Step 2 - 3
Test fitting backplate to mounting screws

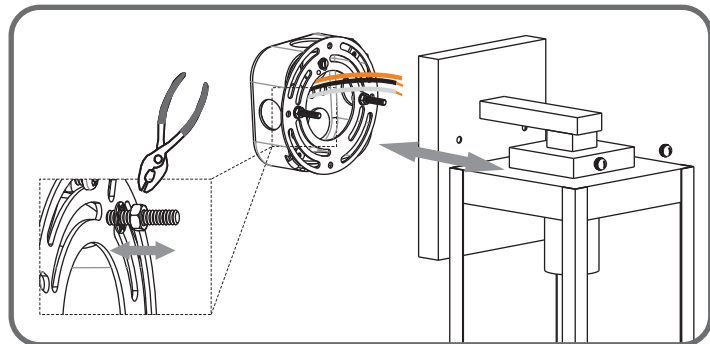
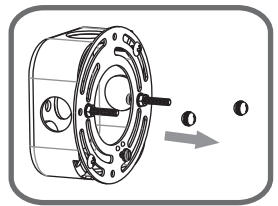

STEP 3

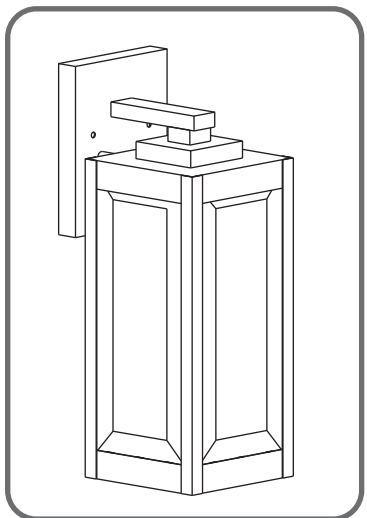
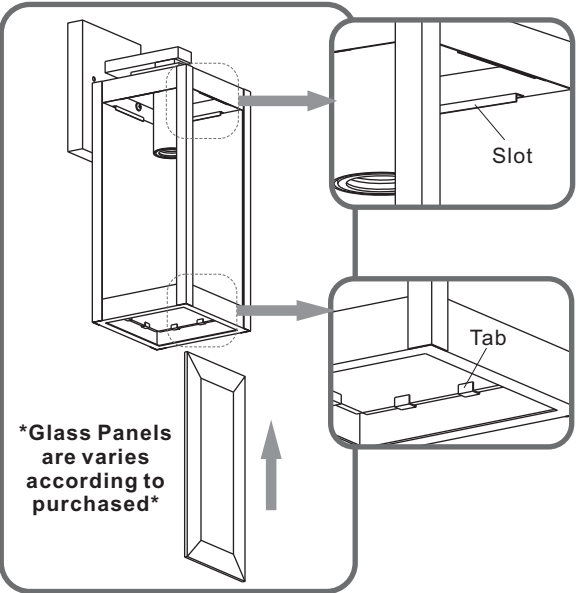

STEP 4

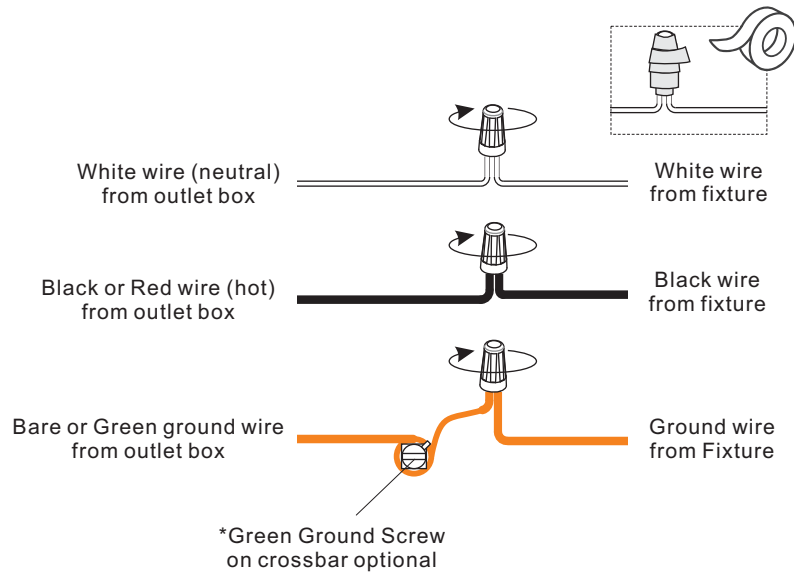

STEP 5

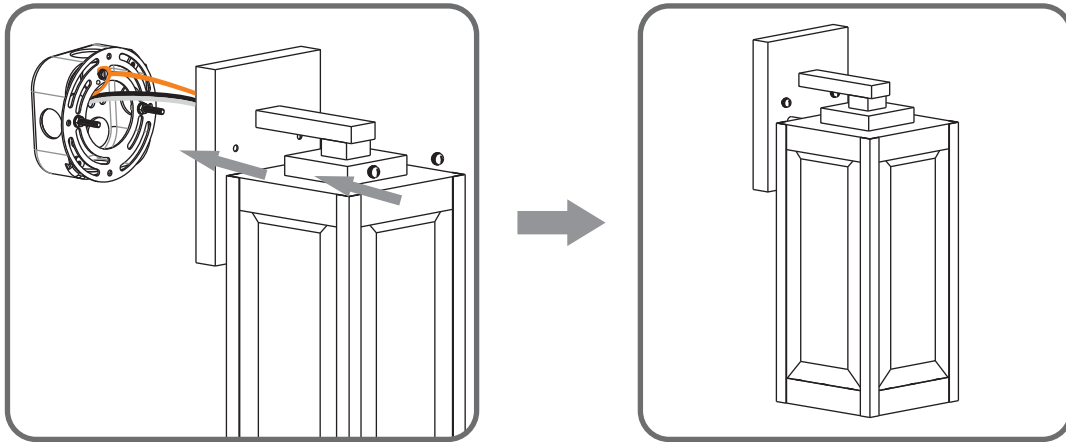

STEP 6

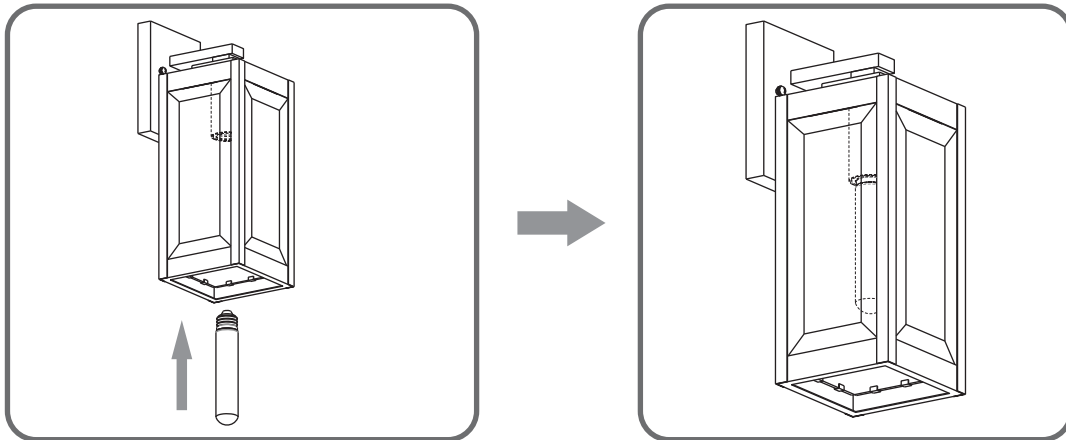

STEP 7

