

INSTALLATION INSTRUCTION

Aether 2" Shallow Recessed Housing

WAC LIGHTING
Responsible Lighting®

HR-2LED-H13A

SAFETY INSTRUCTIONS

IMPORTANT: NEVER attempt any work without shutting off the electricity.

- Read all instructions before installing.
- System is intended for installation by a qualified electrician in accordance with the National Electrical Code and local regulations.
- Place the wall switch in the "OFF" position.
- Go to the main fuse box or circuit breaker. Unscrew the fuse(s) or switch "OFF" the circuit breaker switch(es) that control the power to the space that you are working on.

CAUTION:

All parts must be used as indicated in these instructions. Do not substitute any parts, leave parts out, or use any parts that are worn out or broken. Failure to follow these instructions could invalidate the ETL/cETL listing of this fixture.

AVERTISSEMENT

IMPORTANT : COUPEZ L'ÉLECTRICITÉ AVANT TOUTE MANIPULATION.

- Lisez toutes les instructions avant d'installer.
- Système est destiné à être installé par un électricien qualifié en conformité avec le code national de l'électricité et les règlements locaux.
- Placez l'interrupteur mural en position d'arrêt (« OFF »).
- Accédez au panneau central de disjoncteurs ou de fusibles de votre demeure et placez l'interrupteur principal en position d'arrêt (« OFF »).

MISE EN GARDE

Toutes les pièces doivent être utilisées tel qu'il est indiqué dans ces instructions. Ne remplacez pas les pièces, n'en laissez pas de côté et ne les utilisez pas si elles sont usées ou brisées. Le non-respect de ces instructions peut annuler l'homologation ETL/cETL du luminaire.

OVERVIEW:

This housing is new construction IC Rated and AIRTIGHT. It requires a trim for finished look. Check our catalog or website for compatible trim choices.

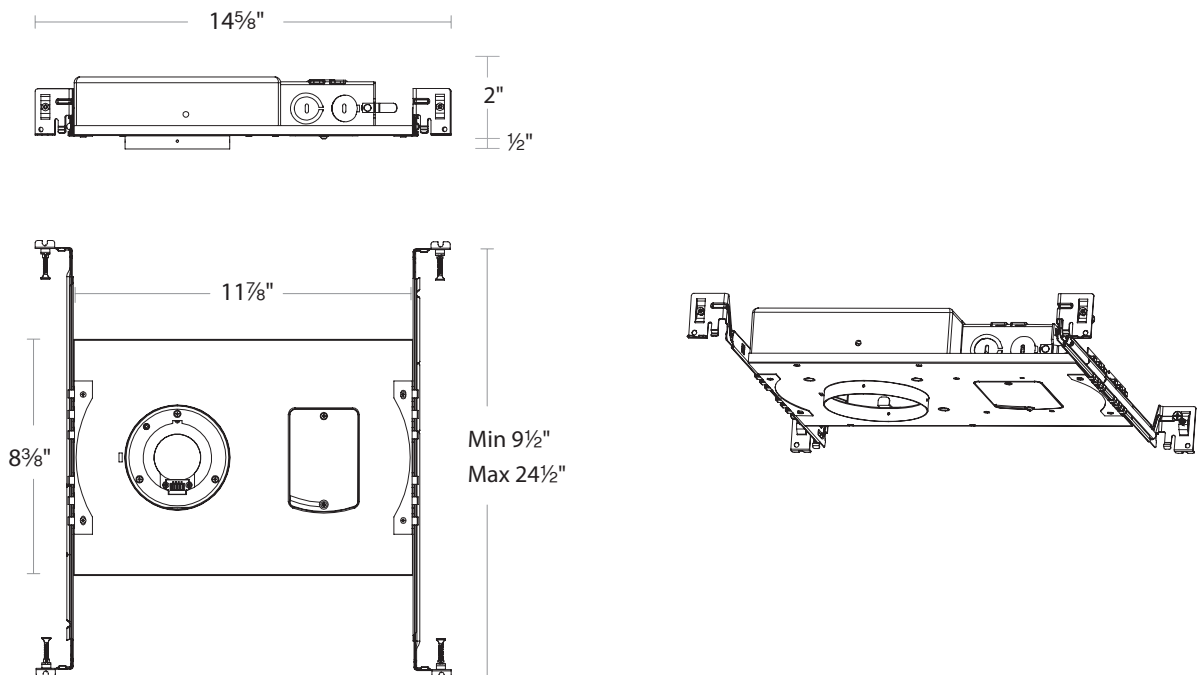

wacighting.com
Phone (800) 526.2588
Fax (800) 526.2585

Headquarters/Eastern Distribution Center
44 Harbor Park Drive
Port Washington, NY 11050

Central Distribution Center
1600 Distribution Ct
Lithia Springs, GA 30122

Western Distribution Center
1750 Archibald Avenue
Ontario, CA 91760

INSTALLATION INSTRUCTION

Aether 2" Shallow Recessed Housing

HR-2LED-H13A

WAC LIGHTING

Responsible Lighting®

HOUSING INSTALLATION:

1. Install housing using two hanger bars provided. Align the bottom of the hanger bar with the bottom of the joist. Secure the "screw-nail" on each end by screwdriver or by hammer (See **FIG.1**, detail A).

Slide fixture along hanger bar into the desired location, use locking screws to secure (See **FIG.1**, detail B).

For grid installation, hanger bars are supported on grids (See **FIG.2**).

2. To shorten hanger bars to fit in a 12" joist, snap off one section of the hanger bars (See **FIG.3**).

3. Remove spring latched junction box cover and connect fixture wires to building wires. Insert each supply wire into appropriate junction box connector. Connect black fixture wire to hot, white fixture wire to neutral, green fixture wire to ground, grey fixture wire to Dim (-) and purple fixture wire to Dim (+) (See **FIG.4**).

To utilize ELV, wire black (line hot) and white (line neutral) in accordance to dimmer specifications. To utilize 0-10V dimming, wire purple (dim+), gray (dim-), black (line hot), and white (line neutral) in accordance to dimmer specifications. When not using a dimmer, connect black fixture wire to hot, white fixture wire to neutral and green fixture wire to ground. Leave all other wires capped individually.

Place all wiring and connectors back in junction box and replace the junction box's cover.

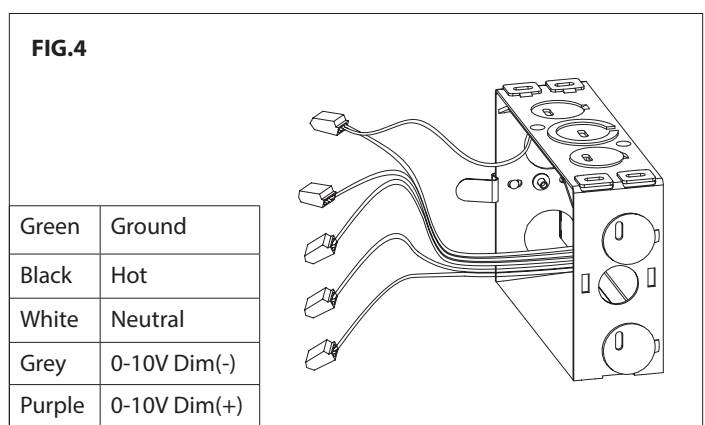
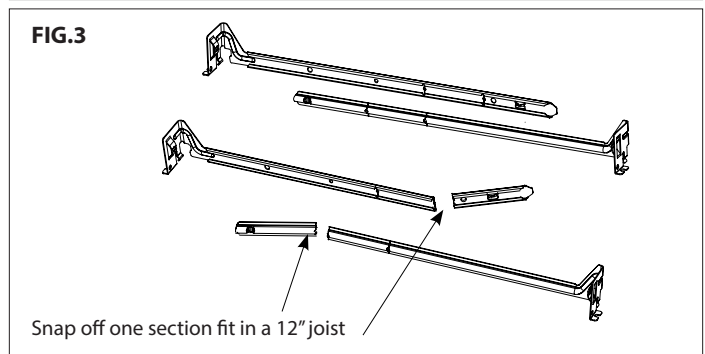
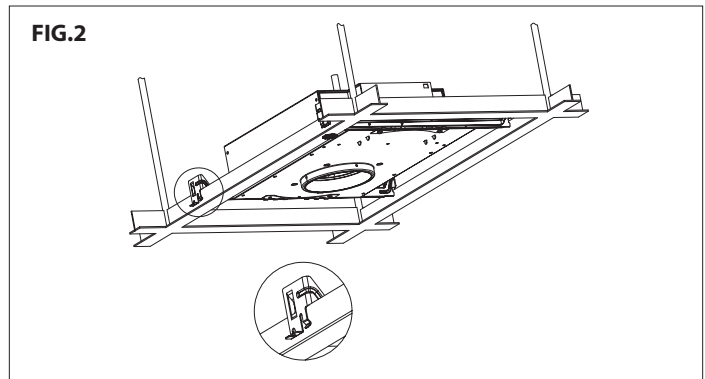
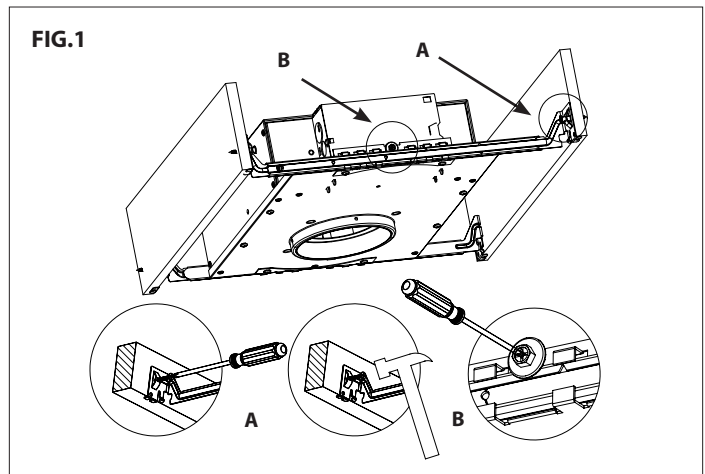

waclighting.com
Phone (800) 526.2588
Fax (800) 526.2585

Headquarters/Eastern Distribution Center
44 Harbor Park Drive
Port Washington, NY 11050

Central Distribution Center
1600 Distribution Ct
Lithia Springs, GA 30122

Western Distribution Center
1750 Archibald Avenue
Ontario, CA 91760

INSTALLATION INSTRUCTION

Aether 2" Shallow Recessed Housing

HR-2LED-H13A

WAC LIGHTING

Responsible Lighting®

OPTIONAL WIRING INSTALLATION

1. Unscrew the housing cover from the base (**Fig.1**).
2. Swivel the housing cover to open (**Fig.2**).
3. To utilize ELV, wire black (line hot) and white (line neutral) in accordance to dimmer specifications. To utilize 0-10V dimming, wire purple (dim +), gray (dim -), black (line hot), and white (line neutral) in accordance to dimmer specifications (**Fig.3**).
When not using a dimmer, connect black fixture wire to hot, white fixture wire to neutral and green fixture wire to ground. Leave all other wires capped individually.
4. Close the door and screw to secure once finished.

FIG.1

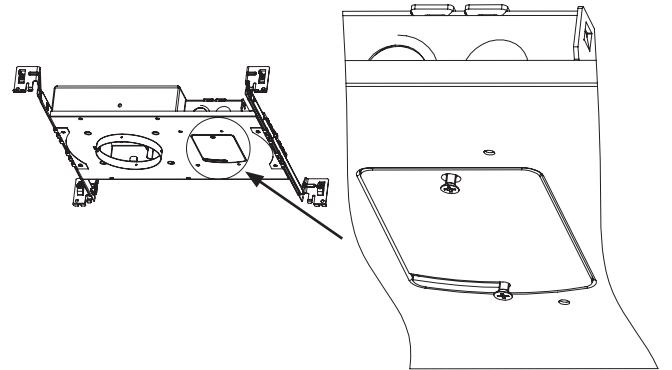

FIG.2

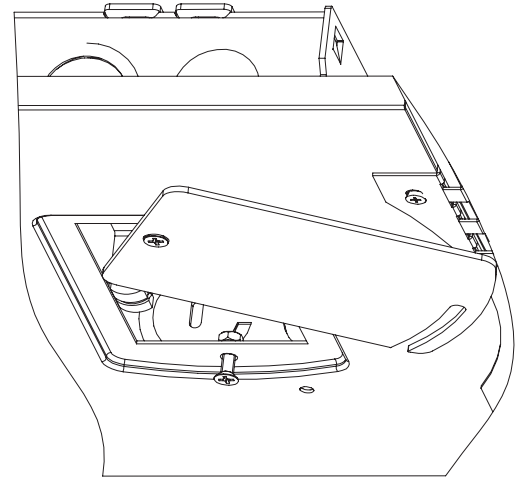
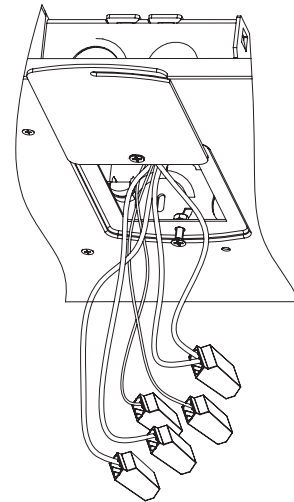

FIG.3



waclighting.com
Phone (800) 526.2588
Fax (800) 526.2585

Headquarters/Eastern Distribution Center
44 Harbor Park Drive
Port Washington, NY 11050

Central Distribution Center
1600 Distribution Ct
Lithia Springs, GA 30122

Western Distribution Center
1750 Archibald Avenue
Ontario, CA 91760

INSTALLATION INSTRUCTION

Aether 2" Shallow Recessed Housing

HR-2LED-H13A

WAC LIGHTING

Responsible Lighting®

HOUSING INSTALLATION

1. When installing the housing that will use the plaster panel, cut a hole with the following dimensions: 4 $\frac{1}{8}$ ".

When installing the housing without the use of the plaster panel, cut a hole with the following dimensions: 3 $\frac{3}{4}$ ".

LIGHT ENGINE INSTALLATION

1. When installing the light engine, there are three options:

For downlight, use figures 1-3.

For adjustable downlight, use figure 4-7.

For wall wash downlight, use figure 8-11.

DOWNLIGHT INSTALLATION

1. Once housing is installed, place the downlight light engine into the housing by aligning both of the small and large slots together. The light engine will magnetically click into (FIG 1 and FIG 2).
2. Raise the trim to housing depress trim spring clips and push the trim assembly up until the trim ring is flush to the ceiling (FIG.3).

ADJUSTABLE DOWNLIGHT INSTALLATION

1. Once housing is installed, place the adjustable downlight light engine into the housing by aligning both of the small and large slots together. The light engine will magnetically click into (FIG 4 and FIG 5).

FIG.1

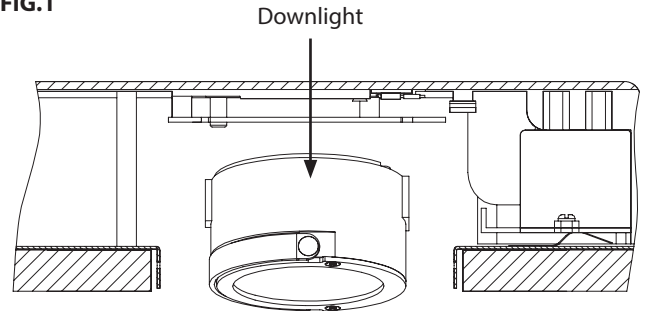

FIG.2

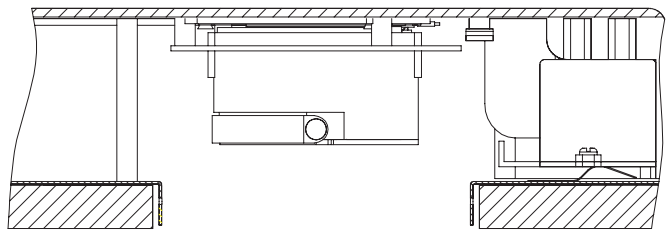

FIG.3

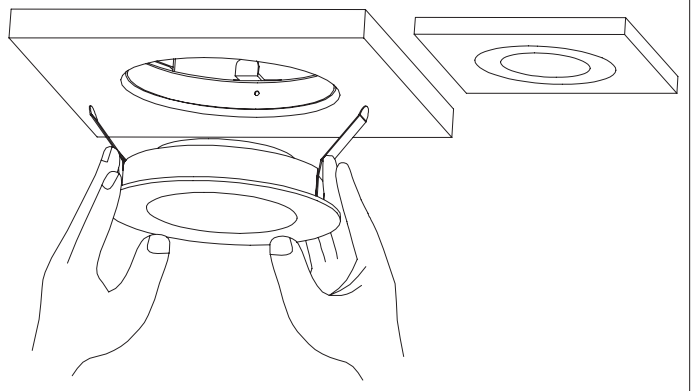
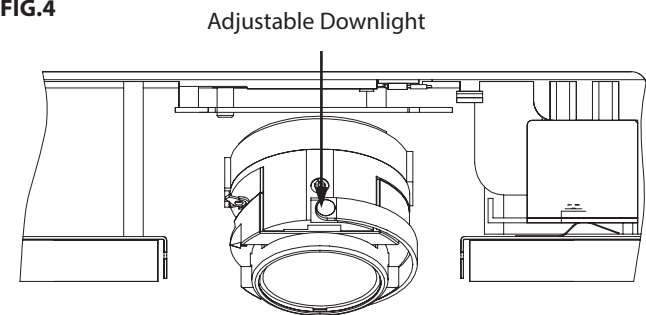

FIG.4



INSTALLATION INSTRUCTION

Aether 2" Shallow Recessed Housing

HR-2LED-H13A

WAC LIGHTING

Responsible Lighting®

ADJUSTABLE DOWNLIGHT INSTALLATION (CONTINUED)

- Note that the adjustable downlight light engine has a max horizontal rotation of 365° and a max vertical rotation of 25° (**FIG 6**).
- Raise the trim to housing, depress trim spring clips and push the trim assembly up until the trim ring is flush to the ceiling (**FIG 7**).

FIG.5

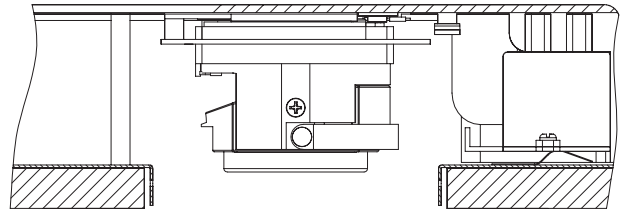
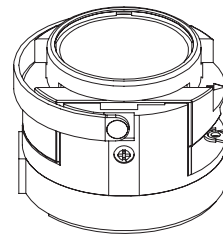
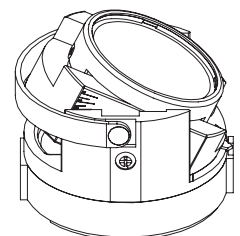

FIG.6



Horizontal: 365°



MAX Vertical: 25°

FIG.7

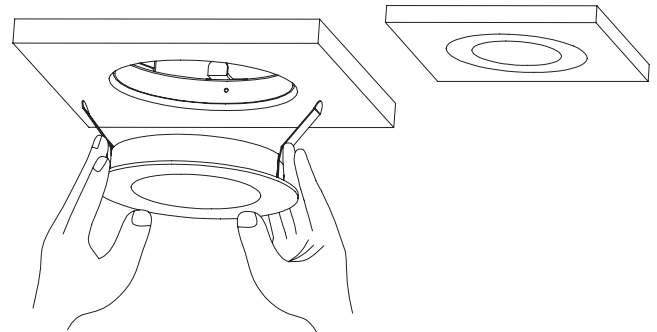

WALL WASH DOWNLIGHT INSTALLATION

- Once housing is installed, place the wall wash downlight light engine into the housing by aligning both of the small and large slots together. The light engine will magnetically click into (**FIG 8** and **FIG 9**).

FIG.8

Wall Wash Downlight

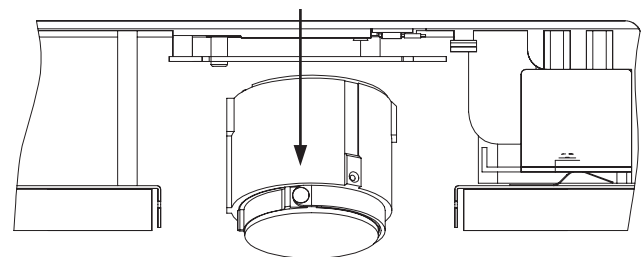

waclighting.com
Phone (800) 526.2588
Fax (800) 526.2585

Headquarters/Eastern Distribution Center
44 Harbor Park Drive
Port Washington, NY 11050

Central Distribution Center
1600 Distribution Ct
Lithia Springs, GA 30122

Western Distribution Center
1750 Archibald Avenue
Ontario, CA 91760

INSTALLATION INSTRUCTION

Aether 2" Shallow Recessed Housing

HR-2LED-H13A

WAC LIGHTING

Responsible Lighting®

WALL WASH DOWNLIGHT TRIM INSTALLATION (CONTINUED)

2. Note that the Wall Wash Downlight Light Engine has a max horizontal rotation of 360 °(Fig. 10).
3. Raise the trim to housing, depress trim spring clips and push the trim assembly up until the trim ring is flush to the ceiling. (Fig. 11).

FIG.9

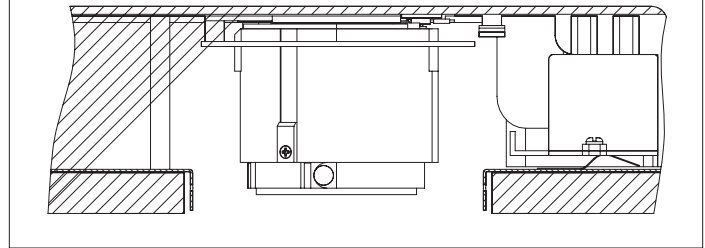

FIG.10

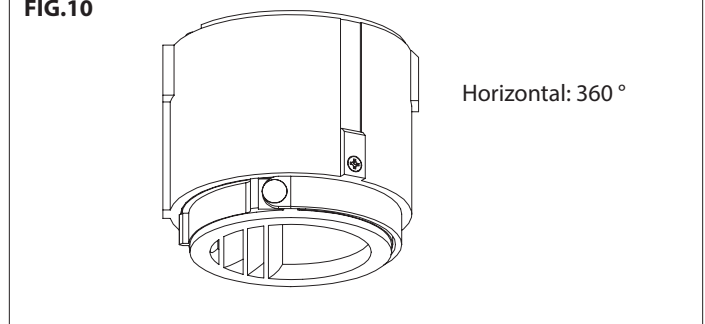
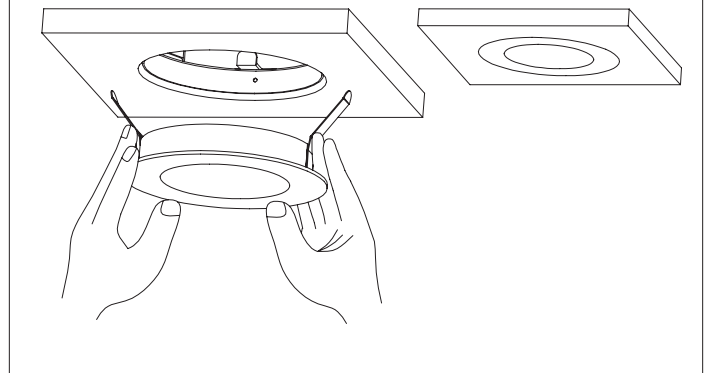

FIG.11



TRIMLESS FRAME INSTALLATION

1. Cut out hole into ceiling with the following dimension: 4 1/8".
2. Raise the trimless frame aligning tab to slot in housing, and put plaster shield inside (See Fig. 12).

FIG.12

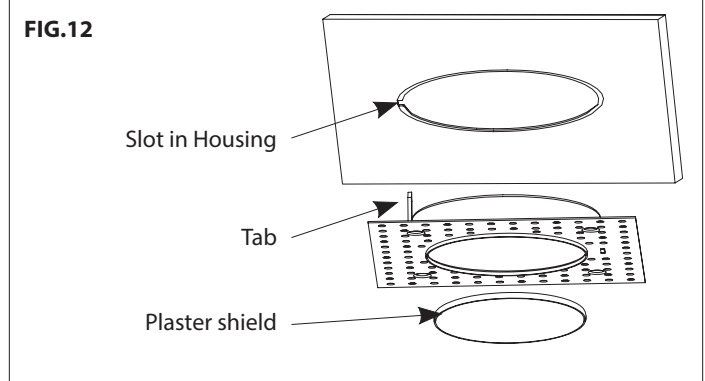

waclighting.com
Phone (800) 526.2588
Fax (800) 526.2585

Headquarters/Eastern Distribution Center
44 Harbor Park Drive
Port Washington, NY 11050

Central Distribution Center
1600 Distribution Ct
Lithia Springs, GA 30122

Western Distribution Center
1750 Archibald Avenue
Ontario, CA 91760

INSTALLATION INSTRUCTION

Aether 2" Shallow Recessed Housing

HR-2LED-H13A

WAC LIGHTING

Responsible Lighting®

TRIMLESS FRAME INSTALLATION (CONTINUE)

- Secure the trimless frame to the housing, flush up against the ceiling using the screws supplied (See **Fig.13**).
- Apply plaster or spackle over trimless frame and sand surface when dry for a finished look (**Fig.14**). Remove the plaster cover when finishing is complete (**Fig.15**).

NOTE: When utilizing the square trim, if position isn't as desired, remove screw, lift the tab and rotate until desired position is acquired.

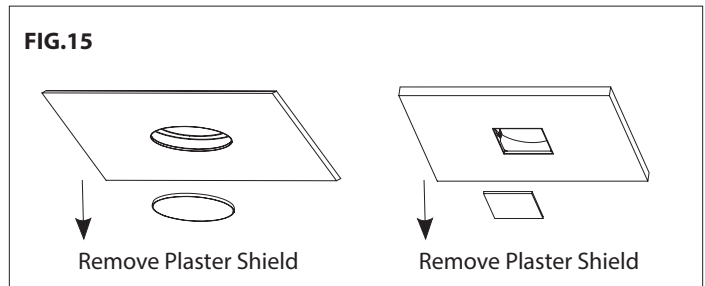
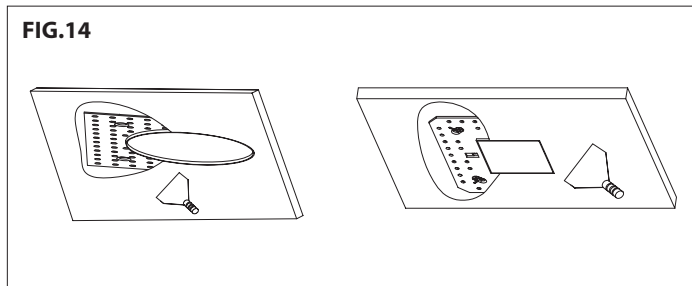
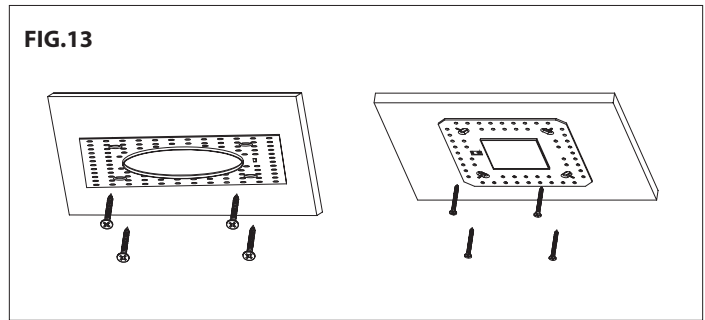

REPLACING THE DRIVER

- Remove Trim Frame from the housing (**FIG.16**).
- Remove Invisible Trim Frame from housing by using a screwdriver to insert between trim top and lens bottom (lens will lift slightly) to remove trim from housing (**FIG.17**).
- Adjust the handle and remove by pulling the light engine from the housing (**FIG.18**).
- With the housing exposed, push in the lock driver clip to free the driver (**FIG.19**).
- Once driver is free from the housing, remove the old driver and replace with the new driver (**FIG.20** and **FIG. 21**).

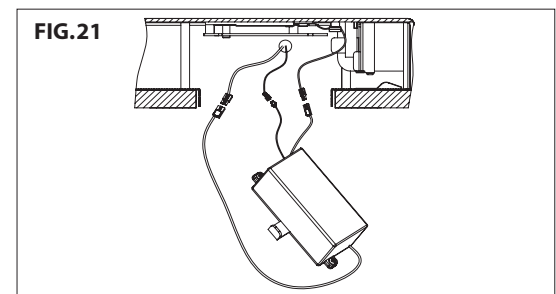
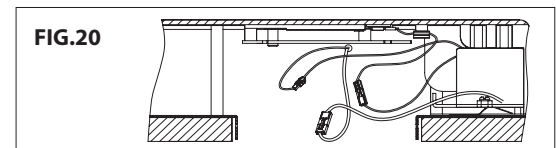
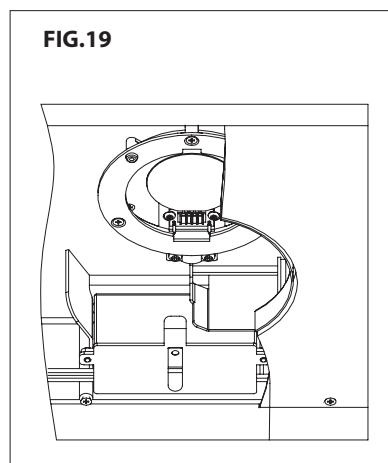
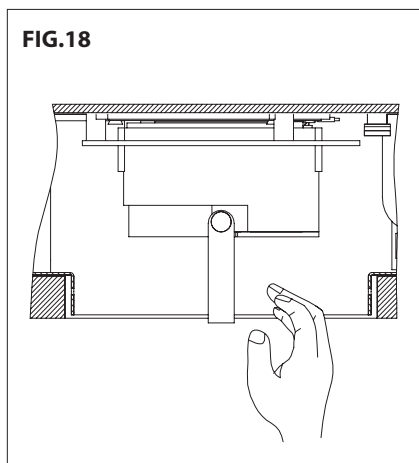
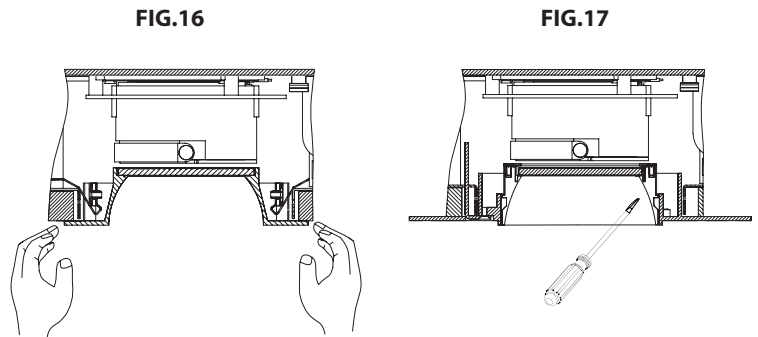

wacighting.com
Phone (800) 526.2588
Fax (800) 526.2585

Headquarters/Eastern Distribution Center
44 Harbor Park Drive
Port Washington, NY 11050

Central Distribution Center
1600 Distribution Ct
Lithia Springs, GA 30122

Western Distribution Center
1750 Archibald Avenue
Ontario, CA 91760